



# Packaged Gas/Electric Rooftop Units

---

Voyager™  
12½ – 25 Tons — 60 Hz





## Introduction

---

# Packaged Rooftop Air Conditioners

Through the years, Trane has designed and developed the most complete line of Packaged Rooftop products available in the market today. Trane was the first to introduce the Micro—microelectronic unit controls—and has continued to improve and revolutionize this design concept.

The ReliaTel control platform offers the same great features and functionality as the original Micro, with additional benefits for greater application flexibility.

Voyager continues to provide the highest standards in quality and reliability, comfort, ease of service, and the performance of Trane light commercial products.

Trane customers demand products that provide exceptional reliability, meet stringent performance requirements, and are competitively priced. Trane delivers with Voyager.

Voyager features cutting edge technologies: reliable compressors, Trane engineered ReliaTel controls, computer-aided run testing, and Integrated Comfort™ Systems. So, whether you're the contractor, the engineer, or the owner you can be certain Voyager Products are built to meet your needs.

It's Hard To Stop A Trane.®



# Contents

---

<b>Introduction</b>	2
<b>Features and Benefits</b>	4
<b>Application Considerations</b>	10
<b>Selection Procedure</b>	11
Model Number Description	13
<b>General Data</b>	14
<b>Performance Data</b>	21
Cooling Performance	21
Fan Performance	31
Heat Performance	43
<b>Controls</b>	46
<b>Electric Power</b>	47
<b>Dimension and Weights</b>	58
<b>Mechanical Specifications</b>	68



# Features and Benefits

---

## Factory Installed Options

- Black Epoxy Coated Condenser Coil
- Dehumidification Option
- High Efficiency Motors
- High Pressure Cutout
- Hinged Access Doors
- Novar Unit Controls
- Novar Return Air Sensor
- Powered or Unpowered Convenience Outlet
- Supply and/or Return Air Smoke Detector
- Thermal Expansion Valve/Face-Split Evaporator Coil Option
- Through the Base Electrical with Circuit Breaker
- Through the Base Electrical With Disconnect Switch
- Through the Base Utilities Access
- Two-Inch Pleated Filters

## Factory or Field Installed Options

- Clogged Filter/Fan Failure Switch
- Differential Pressure Switches
- Discharge Air Sensing Kit
- Downflow – Economizer
- Froststat
- LonTalk® Communications Interface
- Oversized Motors
- Reference or Comparative Enthalpy
- Tool-less Hail Guards
- Trane Communications Interface (TCI)

## Field Installed Options

- CO<sub>2</sub> Sensing
- Digital Display Zone Sensor
- Dual Thermistor Remote Zone Sensor
- Low Static Drive
- High Static Drive
- Manual Outside Air Damper
- Motorized Outside Air Dampers
- Powered Exhaust
- Downflow – Roof Curb
- Horizontal – Economizer
- Remote Potentiometer
- Ventilation Override Accessory
- Zone Sensors

# Features and Benefits

## Easy to Install, Service and Maintain

Because today's owners are very cost-conscious when it comes to service and maintenance, the Trane Voyager was designed with direct input from service contractors. This valuable information helped to design a product that would get the serviceman off the job quicker and save the owner money. Voyager does this by offering:

## Quality and Reliability

### ReliaTel™ Controls (LCI-R)

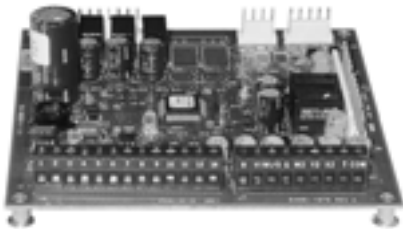

ReliaTel controls provide unit control for heating, cooling and ventilating utilizing input from sensors that measure outdoor and indoor temperature.

Quality and Reliability are enhanced through ReliaTel control and logic:

- prevents the unit from short cycling, considerably improving compressor life.
- ensures that the compressor will run for a specific amount of time which allows oil to return for better lubrication, enhancing the reliability of the compressor.

Voyager with ReliaTel reduces the number of components required to operate the unit, thereby reducing possibilities for component failure.

### ReliaTel Makes Installing and Servicing Easy

ReliaTel eliminates the need for field installed anti-shortcycle timer and time delay relays. ReliaTel controls provide these functions as an integral part of the unit. The contractor no longer has to purchase these controls as options and pay to install them.

The wiring of the low voltage connections to the unit and the zone sensors is as easy as 1-1, 2-2, and 3-3. This simplified system makes wiring easier for the installer.

### ReliaTel Makes Testing Easy

ReliaTel requires no special tools to run the Voyager unit through its paces. Simply place a jumper between Test 1 and Test 2 terminals on the Low Voltage Terminal Board and the unit will walk through its operational steps automatically.

- The unit automatically returns control to the zone sensor after stepping through the test mode a single time, even if the jumper is left on the unit.

As long as the unit has power and the "system on" LED is lit, ReliaTel is operational. The light indicates that the controls are functioning properly.

ReliaTel features expanded diagnostic capabilities when utilized with Trane Integrated Comfort™ Systems.

Some zone sensor options have central control panel lights which indicate the mode the unit is in and possible diagnostic information (dirty filters for example).

### Other ReliaTel Benefits

The ReliaTel built-in anti-shortcycle timer, time delay relay and minimum "on" time control functions are factory tested to assure proper operation.

ReliaTel softens electrical "spikes" by staging on fans, compressors and heaters.

Intelligent Fallback is a benefit to the building occupant. If a component goes astray, the unit will continue to operate at predetermined temperature setpoint.

Intelligent Anticipation is a standard ReliaTel feature. It functions continuously as ReliaTel and zone sensor(s) work together in harmony to provide much tighter comfort control than conventional electro-mechanical thermostats.

The same ReliaTel Board fits all Voyager Packaged Gas/Electrics, Cooling with Electric Heat, and Heat Pump models. This provides standardization of parts for contractors. Less money is tied up in inventory with ReliaTel.

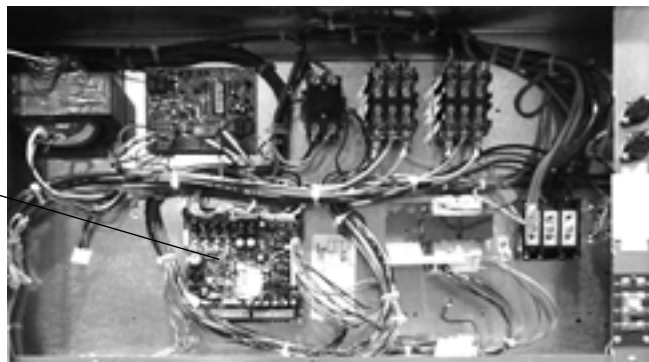

ReliaTel™

# Features and Benefits

---

## Drum and Tube Heat Exchanger

- The heat exchanger is manufactured using aluminized steel with stainless steel components for maximum durability. The requirement for cycle testing of heat exchangers is 10,000 cycles by ANSI Z21.47. This is the standard required by both UL and AGA for cycle test requirements. American Standard requires the design to be tested to 2½ times this current standard. The drum and tube design has been tested and passed over 150,000 cycles, which is over 15 times the current ANSI cycling requirements.
- The negative pressure gas valve will not allow gas flow unless the combustion blower is operating. This is one of our unique safety features.
- The forced combustion blower supplies pre-mixed fuel through a single stainless steel burner screen into a sealed drum where ignition takes place. It is more reliable to operate and maintain than a multiple burner system.
- The hot surface ignitor is a gas ignition device which doubles as a safety device utilizing a continuous test to prove the flame. The design is cycle tested at the factory for quality and reliability.
- Our gas/electric rooftops exceed all California seasonal efficiency requirements and perform even better than the California NOx emission requirements.

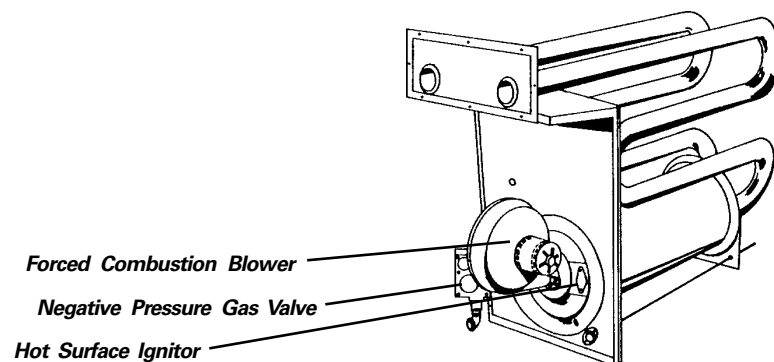

*Drum and Tube Heat Exchanger*

# Features and Benefits

## Outstanding Standard and Optional Components

### Black Epoxy Coated Condenser Coil

The coil provides corrosion protection to condenser coils for seacoast application.

### Cabinet Integrity

For added water integrity, Voyager has a raised  $1\frac{1}{8}$ " lip around the supply and return of the downflow units to prevent water from blowing into the ductwork.

### Clogged Filter/Fan Failure Switch

A dedicated differential pressure switch is available to achieve active fan failure indication and/or clogged filter indication.

### CO<sub>2</sub> Sensing

The CO<sub>2</sub> sensor has the ability to monitor space occupancy levels within the building by measuring the parts per million of CO<sub>2</sub> (Carbon Dioxide) in the air. As the CO<sub>2</sub> levels increase, the outside air damper modulates to meet the CO<sub>2</sub> space ventilation requirements. The CO<sub>2</sub> sensor kit is available as a field installed accessory.

### Colored And Numbered Wiring

Save time and money tracing wires and diagnosing the unit.

### Compressors

Voyager contains the best compressor technology available to achieve the highest possible performance. Dual compressors are outstanding for humidity control, light load cooling conditions and system back-up applications. Dual compressors are available on all models.

### Refrigerant Circuits

All Voyager 12½-25 ton units shall have crankcase heaters, low and high pressure controls as standard.

### Condenser Coil

Voyager boasts a patent-pending 1+1+1 condenser coil, permanently gapped for easy cleaning.

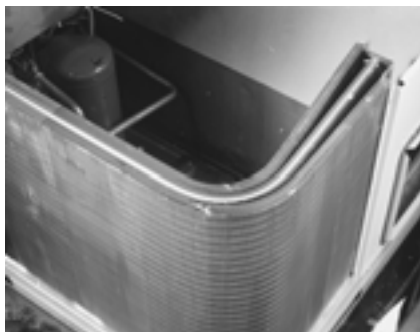

### Dehumidification (Hot Gas Reheat) Option

This option allows for increased outdoor air ventilation. It reduces humidity levels while increasing comfort level in the air space. Cooling can operate without a demand for dehumidification. The hot gas reheat coil is designed to deliver maximum reheat temperature.



### Digital Display Zone Sensor

The Digital LCD (Liquid Crystal Display) zone sensor has the look and functionality of standard zone sensors. This sensor should be utilized with ReliaTel™ controls.

### Discharge Air Sensing Kit

Provides true discharge air sensing in heating models. The kit is functional only with the ReliaTel Options Module.

### Downflow And Horizontal Economizers

The economizers come with three control options — dry bulb is standard, enthalpy and differential enthalpy are optional.

### Dual Thermistor Remote Zone Sensor

This sensor will reduce the total number of remote sensors to obtain space temperature averaging. This sensor should be utilized with ReliaTel controls.

### Factory Built Roof Curbs

Available for downflow units. Only two roof curbs for the entire Voyager line simplifies curb selection.

### Fresh Air

0 - 25% manual or 0 - 50% motorized outside air hoods are available.

### Low Static Drive Accessory

This option shall allow the standard motor to operate at lower static performance. (See Fan Performance tables).

### High Static Drive Accessory

Available on many models, this high static drive accessory extends the capability of the standard motor. Avoid expensive motors and operating costs by installing this optimized sheave accessory.

### Hinged Access Doors

These doors permit easy access to the filter, fan/heat, and compressor/control sections. They reduce the potential roof damage from screws or sharp access door corners.

### LonTalk® Communications Interface

The LonTalk communications interface allows the unit to communicate as a Tracer™ LCI-V device or directly with generic LonTalk Network Building Automation System Controls.

### Power Exhaust Option

This option is available on downflow units and provides exhaust of the return air, when using a downflow economizer, to maintain proper building pressurization. Great for relieving most building overpressurization problems.

### Quick-Access Panels

Remove three or fewer screws for access to the standardized internal components and wiring.

### Quick-Adjust Idler Arm

With the Quick-Adjust Idler Arm, the belt and sheaves can be quickly adjusted without moving the mounted fan motor. The result is a major savings in time and money.





# Features and Benefits

**Reference or Comparative Enthalpy**  
Measures and communicates humidity while maximizing comfort control.

**Sloped Drain Pans**  
Standard on every unit.

**Standardized Components**  
Components are placed in the same location on all Voyager units. Familiarize yourself with one Voyager and you are familiar with every Voyager.

Due to standardized components throughout the Voyager line, contractors/owners can stock fewer parts.

**Supply and/or Return Air Smoke Detector**

With this option installed, if smoke is detected, all unit operation will be shut down. Reset will be manual at the unit. Return Air Smoke Detectors require minimum allowable airflow when used with certain models.



**Tool-less Hail Guards**  
Tool-less, hail protection quality coil guards shall be either

factory or field-installed for condenser coil protection. This option protects the condenser coil from vandalism and/or hail damage.



**Trane Communication Interface (TCI)**  
Available factory or field installed. This module when applied with the ReliaTel™ easily interfaces with Trane's Integrated Comfort™ System.

**VariTrac**  
When Trane's changeover VAV System for light commercial applications is coupled with Voyager, it provides the latest in technological advances for comfort management systems and can allow thermostat control in every zone served by VariTrac.

**Ventilation Override Accessory**  
With the Ventilation Override Accessory installed, the unit can be set to transition to up to 3 different pre-programmed sequences for Smoke Purge, Pressurization, and Exhaust. The transition occurs when a binary input on the RTOM is closed (shorted). This would typically be a hard wired relay output from a smoke detector or fire control panel. The ventilation override kit is available as a field installed accessory.

**Zone Sensors**  
Available in programmable, automatic and manual styles.

**Rigorous Testing**  
The fan and idler arm assembly designs have been tested to over 300,000 cycles each. Our combined cycle testing is now over 7,000,000 cycles.

All of Voyager's designs were rigorously rain tested at the factory to ensure water integrity.

Actual shipping tests were performed to determine packaging requirements. Units were test shipped around the country to determine the best packaging. Factory shake and drop tests were used as part of the package design process to help assure that the unit arrives at the job site in top condition.

Rigging tests include lifting a unit into the air and letting it drop one foot, assuring that the lifting lugs and rails hold up under stress.

We perform a 100% coil leak test at the factory. The evaporator and condenser coils are leak tested at 200 psig and pressure tested to 450 psig.

All parts are inspected at the point of final assembly. Sub-standard parts are identified and rejected immediately.

Every unit receives a 100% unit run test before leaving the production line to make sure it lives up to rigorous Trane requirements.

Voyager units incorporate either a one piece top or the Trane-Tite-Top (T<sup>3</sup>). Each part of the top (either two or three pieces) overlaps in such a way that water cannot leak into the unit. These overlapped edges are gasketed and sealed to ensure superior water integrity.

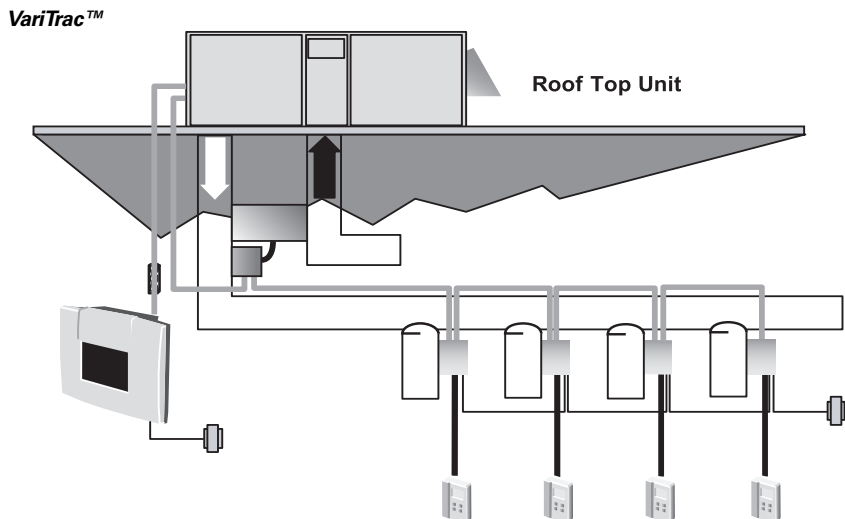



# Features and Benefits

## Easy to Install and Service

### Conversionless Units

The dedicated design units (either downflow or horizontal) require no panel removal or alteration time to convert in the field — a major cost savings during installation.

Horizontal units come complete with duct flanges so the contractor doesn't have to field fabricate them. These duct flanges are a time and cost saver.

### Easy Access Low Voltage Terminal Board

Voyager's Low Voltage Terminal Board is external to the electrical control cabinet. It is extremely easy to locate and attach the thermostat wire. This is another cost and time saving installation feature.



### Low Voltage Connections

The wiring of the low voltage connections to the unit and the zone sensors is as simple as 1-1, 2-2, and 3-3. This simplified system makes it easy for the installer to wire.

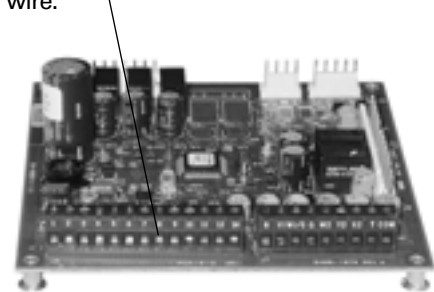

### Powered or Unpowered Convenience Outlet

This option is a GFCI, 120v/15amp, 2 plug, convenience outlet, either powered or unpowered. This option can only be ordered when the Through the Base Electrical with either the Disconnect Switch, or Circuit Breaker, option is ordered. This option is available on all downflow models.



### Single Point Power

A single electrical connection powers the unit.

### Single Side Service

Single side service is standard on all units.

### Through the Base Electrical with Circuit Breaker

This option is a factory installed thermal magnetic, molded case, HACR Circuit Breaker with provisions for through the base electrical connections. This option is available on all downflow models.

### Through the Base Electrical with Disconnect Switch

Factory installed 3-pole, molded case, disconnect switch with provisions for through the base electrical connections are available. This option is available on all downflow models.

### Through the Base Utilities Access

An electrical service entrance shall be provided allowing electrical access for both control and main power connections inside the curb and through the base of the unit. Option will allow for field installation of liquid-tight conduit and an external field installed disconnect switch.

## Factory Installed Options

A wide variety of Factory Installed Options (FIOPs) are available.

## Added Efficiency

### Airflow

Airflow is outstanding. The Voyager can replace an older machine with old ductwork and, in many cases, improve the comfort through better air distribution.

### High Efficiency Motors

This option is available with efficiency ratings from 86.5 up to 91.0. It is not available for all models.

### U-shaped Airflow

U-shaped airflow allows for improved static capabilities.

### Low Ambient Cooling

Cooling capabilities down to 0°F as standard.

### Oversized Motors

Factory or field installed oversized motors available for high static applications.

### One of our Finest Assets:

Trane Sales Representatives are a Support group that can assist you with:

- Product
- Application
- Service
- Training
- Special Applications
- Specifications
- Computer Programs and much more

Voyager has the features and benefits that make it first class in the light commercial rooftop market. Designed with input from field contractors and engineers, its U-shaped airflow performance is outstanding.



# Application Considerations

---

Application of this product should be within the cataloged airflow and cooling considerations.

## Low Ambient Cooling

This Voyager line features, as standard, low ambient cooling down to 0°F. The Voyager™ line features, with ReliaTel™ microprocessor controls, low ambient cooling down to 0°F. The following options need to be included/considered when low ambient applications are required: continuous fan operation, crankcase heaters, thermal expansion valves, frostat. Contact your local Trane Representative for more assistance with low ambient cooling applications.

## Barometric Relief

This product offers an optional barometric relief damper included in the downflow economizer accessory. This accessory consists of gravity dampers which open with increased pressure. As the building air pressure increases, the pressure in the unit return air section also increases, opening the dampers and relieving the conditioned space.

NOTE: THE EFFECTIVENESS OF BAROMETRIC RELIEF DAMPER DURING ECONOMIZING OPERATION IS SYSTEM RELATED. PRESSURE DROP OF THE RETURN AIR SYSTEM SHOULD BE CONSIDERED TO CONTROL BUILDING PRESSURIZATION.

## Heating Operation

The heat exchanger is manufactured with aluminized steel. To prevent condensation within the heat exchanger, do not exceed 50% outside air.

## Power Exhaust Accessory

The power exhaust accessory is available on all 12½-25 tons downflow units. This accessory can be field installed and will assist in relieving building pressurization.

## Condensate Trap

The evaporator is a draw-thru configuration. A trap must be field provided prior to start-up on the cooling cycle.

## Clearance Requirements

The recommended clearances identified with unit dimensions should be maintained to assure adequate serviceability, maximum capacity and peak operating efficiency. Actual clearances which appear inadequate should be reviewed with the local Trane sales personnel.

## Unit Pitch

These units have sloped condensate drain pans. Units must be installed level; any unit slope must be toward access side of unit.

# Selection Procedures

## Cooling Capacity

**Step 1** — Calculate the building's total and sensible cooling loads at design conditions. Use the Trane calculation form or any other standard accepted method.

Example: The following are the building requirements:

- a. Electrical Characteristics: 460/60/3
- b. Summer Design Conditions: Entering Evaporator Coil: 80° DB/ 67° WB  
Outdoor Ambient: 95° DB
- c. Total Cooling Load: 220 MBh
- d. Sensible Cooling Load: 140 MBh
- e. Airflow: 8000 cfm External Static Pressure: 0.450 in wg
- f. downflow configuration
- g. economizer

**Step 2** — As a starting point, a rough determination must be made of the size of the unit. The final selection will be made after examining the performance at the given conditions. Divide the total cooling load by the nominal BTUH per ton (12 MBh per ton); then round up to the nearest unit size.

$$220 \text{ MBh} / 12 \text{ MBh} = 18.333 \text{ (approx 20 tons)}$$

**Step 3** — Examine gross capacity: Table PD-4 shows that a YC\*240B3 has a gross cooling capacity of 246 MBh and 176 MBh sensible capacity at 95 DB ambient and 8000 cfm with 80 DB/ 67 WB air entering the evaporator.

### To Find Capacity at Intermediate Conditions Not in the Table

When the design conditions are between two numbers that are in the capacity table, interpolation is required to approximate the capacity.

Note: Extrapolation outside of the table conditions is not recommended.

**Step 4** — Verify the unit will have enough capacity to meet the building requirements by determining the net capacity, which includes heat generated by the fan. In order to select the correct unit, the fan motor heat must be deducted from the gross cooling capacity. The amount of heat that the fan motor generates is dependent on the effort by the motor - cfm and static pressure.

To determine the total unit static pressure add the external static pressure to the additional static created by the added features:

External Static (duct system) 0.45 wg

Standard Filter 2 in. (from Table PD-36) 0.11 g

Economizer (100% Return Air from Table PD-20) 0.05 wg

Total static pressure 0.61

Note: The Evaporator Fan Performance Table PD-20 has already accounted for the pressure drop for standard filters and wet coils (see note below Table PD-20). Therefore the actual total static pressure is  $0.61 - 0.11 = 0.50$  wg.

With 8000 cfm and 0.50 inches external static pressure. Table PD-20 shows 3.96 bhp for this model. At these conditions, the note below the table gives a formula to calculate Fan Motor Heat:

$$3.15 \times \text{bhp} = \text{MBh}$$

$$3.15 \times 3.96 = 12.47 \text{ MBh}$$

Subtracting the fan motor heat from the gross cooling capacity of the unit:

$$\text{Net Total Cooling Capacity} =$$

$$246 \text{ MBh} - 12.47 = 233.53 \text{ MBh}$$

$$\text{Net Sensible Cooling Capacity} =$$

$$176 \text{ MBh} - 12.47 = 163.53 \text{ MBh}$$

Since the Net Total Cooling Capacity meets the cooling load requirements of 220 MBh, we are satisfied with this selection.

## Heating Capacity

**Step 1** — Calculate the building heating load using the Trane calculation form or other standard accepted method.

**Step 2** — Size the system heating capacity to match the calculated building heating load. The following are building heating requirements:

- a. Total heating load of 165 MBh
- b. 8000 cfm
- c. Fuel - Natural gas

For the YC\*240B3, there are two heating capacities available, 250 MBh and 400 MBh input models shown in Table PD-35. The output capacities of these furnaces are 175 MBh and 300 MBh respectively. The low heat model with 175 MBh best matches the building requirements, indicating a YC\*240B3 should be selected.

## Air Delivery Selection

External static pressure drop through the air distribution system has been calculated to be 0.50 inches of water. Enter Table PD-20 for a YC\*240B3 at 8000 cfm and 0.50 static pressure. The standard motor at high speed will give the desired airflow.

## Accessory Selection

Select accessories needed to accommodate the application.

# Selection Procedure

## Dehumidification Selection

Determine normal unit cooling and heating capacities as previously described in the selection procedures on prior page.

Typical 20 ton YFD241C  
 6400 cfm Total Supply airflow  
 2560 cfm Outside Air (40%)  
 3840 cfm Return Air  
 1.00" External Static Pressure

### OA Conditions

*Part load day and raining*  
 68°F db  
 67°F wb  
 66.5 dp  
 95% RH

### RA conditions

75°F db  
 63°F wb  
 52% RH  
 55.9 dp

### Step 1: Determine the mixed/entering air condition (MA')

MA' = (% outside air\*outside air dry-bulb temperature) + (% return air\*return air dry-bulb temperature)

$$MA' = (0.40*68°F) + (0.60*75°F)$$

$$MA' = 72.20°F \text{ db}$$

### Note: Repeat for wet-bulb temperature (wb).

Plot on psychrometric chart.

### MA'

72.2°F db  
 64.7°F wb

### Step 2: Determine the additional static pressure drop for a reheat unit

Table PD-36 shows a static pressure drop of 0.35" for the reheat coil and an additional .04 for the mandatory 2" pleated filters required when ordering the dehumidification option. Total static pressure =

$$1.0 + 0.035 + 0.04 = 1.075$$

$$(\geq 1.1 \text{ for manual calculations})$$

Do not forget to also add any additional static from other accessories.

Table PD-29 (airflow table for 20 ton dehumidification units) indicates that a standard motor and drive is needed for this airflow and static pressure range.

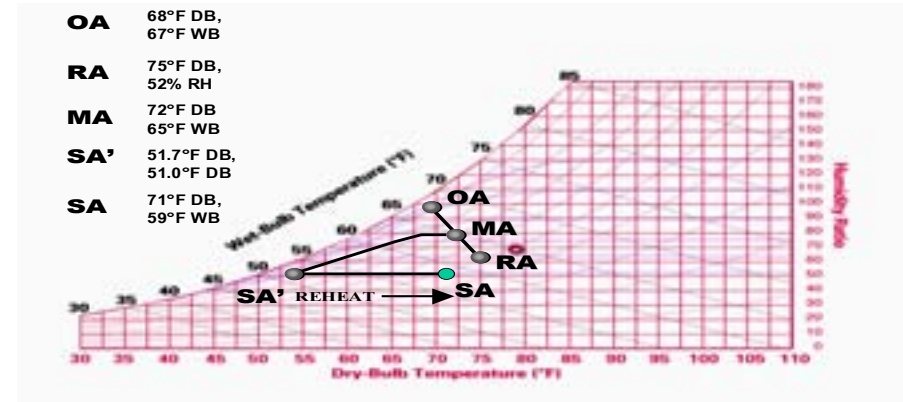

Chart C-1

### Step 3a: Determine leaving evaporator temperature (SA')

Leaving Unit Temperature = SA'

Utilizing the manual selection method as previously described and the formula

$$\Delta \text{Temp} = \frac{\text{gross sensible or latent cooling capacity in Bth}}{(\text{cfm})(1.085)}$$

Subtract your sensible  $\Delta$  temp from the entering db and latent  $\Delta$  temp from the entering wb or use the TOPSS™ program determine the leaving evaporator temperature (temperature without the addition of fan heat).

51.74 db  
 51.03 wb

### Step 3b: Determine leaving unit temperature in standard cooling mode

Repeat Step 3a substituting net sensible or latent capacity for gross sensible or latent capacity to find the leaving unit temperature including fan heat or refer to your TOPSS selection.

53.6 db  
 51 wb  
 84% RH  
 49% dp

### Step 4: Determine reheat temperature rise

Using the leaving evaporator temp (SA'), go to PD-37 and determine the reheat temperature rise for that particular cfm: 17.55°F db

Note: Reheat temperature rise is based on **supply airflow** and leaving **evaporator coil** temperature.

### Step 5: Determine leaving unit sensible temperature with reheat active (SA)

Reheat temperature (obtained in step 4) + (SA' + fan heat) = SA

$$(SA' + \text{fan heat}) = \text{leaving unit temperature in standard cooling mode from step 3b.}$$

$$17.55°F \text{ db} + 53.6°F = 71.2°F \text{ db}$$

$$SA = 71.2°F$$

Since reheat adds only sensible heat, follow the psychrometric chart to find the new wb temperature.

$$wb \approx 58.7°F$$

Consider Chart C-1. If the space relative humidity is equal to or above the space relative humidity setpoint, the Dehumidification option will:

- Energize compressor or both compressors (2 stage compressor units).
- Hot gas reheat valve is energized and hot gas is diverted to the reheat coil.
- Dehumidification/reheat is terminated when space humidity is reduced to 5% below relative humidity setpoint.

At MA', air enters the RTU. The RTU filters, cools, and dehumidifies the air as it moves through the evaporator coil. Air leaves the evaporator coil saturated at the preset dew point condition (SA') and is reheated by the hot gas reheat coil to deliver 71°F (SA) supply air to the space.



# Model Number Description

## Packaged Gas/Electric Unit Typical Model Nomenclature

<b>Y</b>	<b>C</b>	<b>D</b>	<b>1</b>	<b>5</b>	<b>0</b>	<b>C</b>	<b>3</b>	<b>L</b>	<b>0</b>	<b>A</b>	<b>A</b>
1	2	3	4	5	6	7	8	9	10	11	12

### **Digits 1, 2 - Product Type**

YC = Packaged Gas/Electric

YF = With Factory Installed Options

### **Digit 3 - Airflow Configuration**

D = Downflow

H = Horizontal

### **Digits 4, 5, 6 - Nominal Gross Cooling Capacity (MBh)**

- 150 = 12½ Ton Standard Efficiency
- 151 = 12½ Ton High Efficiency
- 180 = 15 Ton Standard Efficiency
- 181 = 15 Ton High Efficiency
- 210 = 17½ Ton Standard Efficiency
- 211 = 17½ Ton High Efficiency
- 240 = 20 Ton Standard Efficiency
- 241 = 20 Ton High Efficiency
- 300 = 25 Ton Standard Efficiency
- 301 = 25 Ton High Efficiency

### **Digit 7- Major Development Sequence**

### **Digit 8 - Electrical Characteristics**

3 = 208-230/60/3

4 = 460/60/3

W = 575/60/3

K = 380/60/3

### **Digit 9 - Heating Capacity**

L = Low Heat

M = Medium Heat

H = High Heat

### **Digit 10 - Factory-Installed Options**

0 = Packed Stock, No Options

A = Downflow Economizer

B = Oversized Motor

C = Downflow Economizer and Oversized Motor

F = Trane Communications Interface (TCI)

G = Downflow Economizer and TCI

H = TXV/Face-Split Evaporator

J = Oversized Motor and TXV/Face-Split Evaporator

K = Downflow Economizer, Oversized Motor, and TXV/Face-Split Evaporator

L = Downflow Economizer with TXV/Face-Split Evaporator

M = Reheat Coil

N = Downflow Economizer and Reheat Coil

P = Oversized Motor and Reheat Coil

R = Downflow Economizer, Oversized Motor and Reheat Coil

### **Digit 11- Minor Design Sequence**

### **Digit 12- Service Digit**



# General Data

# (12½, 15 Ton) Standard Efficiency

**Table GD-1 – General Data**

	12½Ton Downflow and Horizontal Units		15Ton Downflow and Horizontal Units	
	YC*150D3,D4,DWL, DK	YC*150D3,D4,DWH, DK	YC*180B3,B4,BWL, BK	YC*180B3,B4,BWH, BK
<b>Cooling Performance<sup>1</sup></b>				
Gross Cooling Capacity	150,000		182,000	
EER <sup>2</sup> (Downflow/Horizontal)	9.6		9.7	
Nominal CFM / ARI Rated CFM	5,000/4,400		6,000/5,300	
ARI Net Cooling Capacity	142,000		174,000	
Integrated Part Load Value <sup>3</sup>	10.3		10.0	
System Power (KW)	14.79		17.94	
<b>Heating Performance<sup>4</sup></b>				
Heating Models	Low	High	Low	High
Heating Input (Btu/h)	150,000	250,000	250,000	350,000
1st Stage	100,000	175,000	175,000	250,000
Heating Output (Btu/h)	122,000	203,000	203,000	284,000
1st Stage	81,000	142,000	142,000	203,000
AFUE (%) <sup>5</sup> (Downflow/Horizontal)	81.0	80.7/79.9	80.7 / 79.9	80.1 / 79.1
Steady State Efficiency (%)	81.0	81.0	81.0	81.0
No. Burners	1		1	
No. Stages	2		2	
Gas Supply Pressure (in. w.c)				
Natural or LP (minimum/maximum)	2.5/14.0		2.5/14.0	
Gas Connection Pipe Size (in.)	1/2		1/2	3/4
<b>Compressor</b>				
No./Type	2/Scrolls		2/Scrolls	
<b>Sound Rating (BELS)<sup>6</sup></b>				
	9.2		9.2	
<b>Outdoor Coil -Type</b>				
	Hi-Performance		Hi-Performance	
Tube Size (in.) OD	.375		.375	
Face Area (sq ft)	24.18		27.12	
Rows/FPI	2/16		3/16	
<b>Indoor Coil -Type</b>				
	Hi-Performance		Hi-Performance	
Tube Size (in.)	.375		.375	
Face Area (sq ft)	17.5		17.50	
Rows/FPI	2/15		2/15	
Refrigerant Control	Short Orifice		Short Orifice	
Drain Connection No./Size (in.)	1/1.00 NPT		1/1.00 NPT	
<b>Outdoor Fan -Type</b>				
	Propeller		Propeller	
No. Used/Diameter (in.)	2/26		2/26	
Drive Type/No. Speeds	Direct/1		Direct/1	
CFM	10,600		10,200	
No. Motors/HP	2/50		2/50	
Motor RPM	1,100		1,100	
<b>Indoor Fan -Type</b>				
	FC Centrifugal		FC Centrifugal	
No. Used/Diameter (in.)	1/15 X 15		1/15 X 15	
Drive Type/No. Speeds	Belt/1		Belt/1	
No. Motors	1		1	
Motor HP (Standard/Oversized) <sup>9</sup>	3.0/5.0		3.0/5.0	
Motor RPM (Standard/Oversized) <sup>9</sup>	1740/3450		1740/3450	
Motor Frame Size (Standard/Oversized) <sup>9</sup>	145T/145T		145T/145T	
<b>Filters -Type Furnished</b>				
(No.) Size Recommended	Throwaway <sup>8</sup>		Throwaway <sup>8</sup>	
Downflow	(2) 20 X 20 X 2, (4) 20 X 25 X 2		(2) 20 X 20 X 2, (4) 20 X 25 X 2	
Horizontal	(2) 20 X 20 X 2, (4) 20 X 25 X 2		(2) 20 X 20 X 2, (4) 20 X 25 X 2	
<b>Refrigerant Charge (Lbs of R-22)<sup>7</sup></b>				
	9.3/9.4/Circuit		17.5/9.5/ Circuit	

- Notes:
- Cooling Performance is rated at 95°F ambient, 80°F entering dry bulb, 67°F entering wet bulb. Gross capacity does not include the effect of fan motor heat. ARI capacity is net and includes the effect of fan motor heat. Units are suitable for operation to ±20% of nominal CFM. Certified in accordance with the unitary large equipment certification program, which is based on ARI Standard 340/360-93.
  - EER is rated at ARI conditions and in accordance with ARI Standard 210/240 or 360.
  - Integrated Part Load Value is rated in accordance with ARI Standard 210/240 or 360. Units are rated at 80°F ambient, 80°F entering dry bulb, and 67°F entering wet bulb at ARI rated cfm.
  - Heating Performance limit settings and rating data were established and approved under laboratory test conditions using American National Standards Institute standards. Ratings shown are for elevations up to 2000 feet. For elevations above 2000 feet, ratings should be reduced at the rate of 4% for each 1000 feet above sea level.
  - AFUE is rated in accordance with DOE test procedures.
  - Sound Rating shown is tested in accordance with ARI Standard 270 or 370.
  - Refrigerant charge is an approximate value. For a more precise value, see unit nameplate and service instructions.
  - An optional 2 inch pleated filter is also available.
  - For 380V/60Hz units, the oversized motor is used as the standard motor. Refer to oversized motor data.

\*Indicates both downflow and horizontal units.



# General Data

# (17½, 20 Ton) Standard Efficiency

**Table GD-2 – General Data**

	17½ Ton Downflow and Horizontal Units		20 Ton Downflow and Horizontal Units	
	YC*210C3,C4,CWL, CK	YC*210C3,C4,CWH, CK	YC*240B3,B4,BWL, BK	YC*240B3,B4,BWH, BK
<b>Cooling Performance<sup>1</sup></b>				
Gross Cooling Capacity	210,000		242,000	
EER <sup>2</sup>	9.6		9.5	
Nominal CFM / ARI Rated CFM	7,000/5,800		8,000/7,000	
ARI Net Cooling Capacity	196,000		232,000	
Integrated Part Load Value <sup>3</sup>	9.8		9.8	
System Power (KW)	20.41		24.42	
<b>Heating Performance<sup>4</sup></b>				
Heating Models	Low	High	Low	High
Heating Input (Btuh)	250,000	350,000	250,000	400,000
1st Stage	175,000	250,000	175,000	300,000
Heating Output (Btuh)	203,000	284,000	203,000	324,000
1st Stage	142,000	203,000	142,000	243,000
AFUE (%) <sup>5</sup> Downflow/Horizontal	80.7 / 79.9	80.1 / 79.1	80.2 / 81.0	79.8 / 79.7
Steady State Efficiency (%)	81.0	81.0	81.0	81.0
No. Burners	1		1	
No. Stages	2		2	
Gas Supply Pressure (in. w.c)	2.5/14.0		2.5/14.0	
Natural or LP (minimum/maximum)				
Gas Connection Pipe Size (in.)	1/2	3/4	1/2	3/4
<b>Compressor</b>				
No./Type	2/Scrolls		2/Scrolls	
<b>Sound Rating (BELS)<sup>6</sup></b>				
	9.4		9.4	
<b>Outdoor Coil - Type</b>				
	Hi-Performance		Hi-Performance	
Tube Size (in.) OD	.375		.375	
Face Area (sq ft)	27.12		35.3	
Rows/FPI	3/16		3/16	
<b>Indoor Coil - Type</b>				
	Hi-Performance		Hi-Performance	
Tube Size (in.)	.375		.375	
Face Area (sq ft)	17.50		26.00	
Rows/FPI	4/15		2/15	
Refrigerant Control	Short Orifice		Short Orifice	
Drain Connection No./Size (in.)	1/1.00 NPT		1/1.00 NPT	
<b>Outdoor Fan - Type</b>				
	Propeller		Propeller	
No. Used/Diameter (in.)	2/26		2/26	
Drive Type/No. Speeds	Direct/1		Direct/1	
CFM	13,400		14,600	
No. Motors/HP	2/1.0		2/1.0	
Motor RPM	1,125		1,125	
<b>Indoor Fan - Type</b>				
	FC Centrifugal		FC Centrifugal	
No. Used/Diameter (in.)	1/15 X 15		1/18 X 18	
Drive Type/No. Speeds	Belt/1		Belt/1	
No. Motors	1		1	
Motor HP (Standard/Oversized) <sup>9</sup>	5.0/7.5		5.0/7.5	
Motor RPM (Standard) <sup>9</sup>	3450/3470		3450/3470	
Motor Frame Size (Standard/Oversized) <sup>9</sup>	56HZ/184T		145T/184T	
<b>Filters - Type Furnished<sup>8</sup></b>				
	Throwaway		Throwaway	
(No.) Size Recommended				
Downflow	(2) 20 X 20 X 2/(4) 20 X 25 X 2		(4) 20 X 20 X 2/(4) 20 X 25 X 2	
Horizontal	(2) 20 X 20 X 2/(4) 20 X 25 X 2		(8) 20 X 25 X 2	
<b>Refrigerant Charge (Lbs of R-22)<sup>7</sup></b>				
Downflow	21.0/14.3/Circuit		18.9/21.0/Circuit	
Horizontal	21.5/14.5/Circuit			

**Notes:**

- Cooling Performance is rated at 95°F ambient, 80°F entering dry bulb, 67°F entering wet bulb. Gross capacity does not include the effect of fan motor heat. ARI capacity is net and includes the effect of fan motor heat. Units are suitable for operation to ±20% of nominal cfm. Certified in accordance with the Unitary Large Equipment certification program, which is based on ARI Standard 340/360-93.
- EER is rated at ARI conditions and in accordance with ARI Standard 210/240 or 360.
- Integrated Part Load Value is rated in accordance with ARI Standard 210/240 or 360. Units are rated at 80°F ambient, 80°F entering dry bulb, and 67°F entering wet bulb at ARI rated cfm.
- Heating Performance limit settings and rating data were established and approved under laboratory test conditions using American National Standards Institute standards. Ratings shown are for elevations up to 2000 feet. For elevations above 2000 feet, ratings should be reduced at the rate of 4% for each 1000 feet above sea level.
- AFUE is rated in accordance with DOE test procedures.
- Sound Rating shown is tested in accordance with ARI Standard 270 or 370.
- Refrigerant charge is an approximate value. For a more precise value, see unit nameplate and service instructions.
- An optional 2 inch pleated filter is also available.
- For 380V/60Hz units, the oversized motor is used as the standard motor. Refer to oversized motor data.

\* Indicates both downflow and horizontal units.



# General Data

# (25 Ton) Standard Efficiency

**Table GD-3 – General Data**

	25 Ton Downflow and Horizontal Units	
	YC*300B3,B4,BWL, BK	YC*300B3,B4,BWH, BK
<b>Cooling Performance<sup>1</sup></b>		
Gross Cooling Capacity	290,000	
EER <sup>2</sup>	9.7	
Nominal CFM / ARI Rated CFM	10,000 / 8,750	
ARI Net Cooling Capacity	272,000	
Integrated Part Load Value <sup>3</sup>	9.8	
System Power (KW)	28.05	
<b>Heating Performance<sup>4</sup></b>		
Heating Models	Low	High
Heating Input (Btuh)	250,000	400,000
1st Stage	175,000	300,000
Heating Output (Btuh)	203,000	324,000
1st Stage	142,000	243,000
AFUE (%) <sup>5</sup> Downflow/Horizontal	80.2/81.0	79.8/79.7
Steady State Efficiency (%)	81.4/81.0	80.8/81.0
No. Burners	1	
No. Stages	2	
Gas Supply Pressure (in. w.c)		
Natural or LP (minimum/maximum)	2.5/14.0	
Gas Connection Pipe Size (in.)	1/2	3/4
<b>Compressor</b>		
No./Type	2/Scrolls	
<b>Sound Rating (BELS)<sup>6</sup></b>	9.4	
<b>Outdoor Coil - Type</b>		
Tube Size (in.) OD	Hi-Performance	
Face Area (sq ft)	.375	
Rows/FPI	36.43	
<b>Indoor Coil - Type</b>		
Tube Size (in.)	Hi-Performance	
Face Area (sq ft)	.375	
Rows/FPI	26.00	
Refrigerant Control	3/15	
Drain Connection No./Size (in.)	Short Orifice	
<b>Outdoor Fan - Type</b>		
No. Used/Diameter (in.)	Propeller	
Drive Type/No. Speeds	2/28	
CFM	Direct/1	
No. Motors/HP	16,700	
Motor RPM	2/1.0	
<b>Indoor Fan - Type</b>		
No. Used/Diameter (in.)	FC Centrifugal	
Drive Type/No. Speeds	1/18 X 18	
No. Motors	Belt/1	
Motor HP (Standard/Oversized) <sup>9</sup>	1	
Motor RPM (Standard/Oversized) <sup>9</sup>	7.5/NA	
Motor Frame Size (Standard/Oversized) <sup>9</sup>	3470/NA	
<b>Filters - Type Furnished<sup>8</sup></b>		
(No.) Size Recommended	Throwaway	
Downflow	(4) 20 X 20 X 2(4) 20 X 25 X 2	
Horizontal	(8) 20 X 25 X 2	
<b>Refrigerant Charge (Lbs of R-22)<sup>7</sup></b>		
Downflow	170/Circuit	
Horizontal		

**Notes:**

- Cooling Performance is rated at 95°F ambient, 80°F entering dry bulb, 67°F entering wet bulb. Gross capacity does not include the effect of fan motor heat. ARI capacity is net and includes the effect of fan motor heat. Units are suitable for operation to ±20% of nominal cfm. YC\*300B model ratings shown are tested in accordance with ARI Standard 340/360-93.
- EER is rated at ARI conditions and in accordance with ARI Standard 210/240 or 360.
- Integrated Part Load Value is rated in accordance with ARI Standard 210/240 or 360. Units are rated at 80°F ambient, 80°F entering dry bulb, and 67°F entering wet bulb at ARI rated cfm.
- Heating Performance limit settings and rating data were established and approved under laboratory test conditions using American National Standards Institute standards. Ratings shown are for elevations up to 2000 feet. For elevations above 2000 feet, ratings should be reduced at the rate of 4% for each 1000 feet above sea level.
- AFUE is rated in accordance with DOE test procedures.
- Sound Rating shown is tested in accordance with ARI Standard 270 or 370.
- Refrigerant charge is an approximate value. For a more precise value, see unit nameplate and service instructions.
- An optional 2 inch pleated filter is also available.
- For 380V/60Hz units, the oversized motor is used as the standard motor. Refer to oversized motor data.

\*Indicates both downflow and horizontal units.





# General Data

## (12½, 15 Ton) High Efficiency

**Table GD-4 — General Data**

	12½Ton Downflow and Horizontal Units YC*151C3,C4,CW		15Ton Downflow and Horizontal Units YC*181C3,C4,CW	
<b>Cooling Performance<sup>1</sup></b>				
Gross Cooling Capacity	154,000		189,000	
EER <sup>2</sup>	11.30 <sup>10</sup>		11.50 <sup>9</sup>	
Nominal CFM / ARI Rated CFM	5,000 / 4400		6,000 / 5,300	
ARI Net Cooling Capacity	146,000		180,000	
Integrated Part Load Value <sup>3</sup>	11.5		13.3	
System Power (KW)	12.92 <sup>10</sup>		15.65 <sup>9</sup>	
<b>Heating Performance<sup>4</sup></b>				
Heating Models	Low	High	Low	High
Heating Input (Btuh)	150,000	250,000	250,000	350,000
1st Stage	100,000	175,000	175,000	250,000
Heating Output (Btuh)	122,000	203,000	203,000	284,000
1st Stage	81,000	142,000	142,000	203,000
AFUE% <sup>5</sup> (Downflow/Horizontal)	81.0 / 81.0	80.7 / 79.9	80.7 / 79.9	80.1 / 79.1
Steady State Efficiency (%) <sup>5</sup>	81.0		81.0	
No. Burners	1	1	1	1
No. Stages	2	2	2	2
Gas Supply Pressure (in. w.c)				
Natural or LP (minimum/maximum)	2.5/14.0		2.5/14.0	
Gas Connection Pipe Size (in.)	1/2	1/2	1/2	3/4
<b>Compressor</b>				
No./Type	2/Scrolls		2/Scrolls	
<b>Sound Rating (BELS)<sup>6</sup></b>	9.2		9.2	
<b>Outdoor Coil - Type</b>				
Type	Hi-Performance		Hi-Performance	
Tube Size (in.) OD	0.375		0.375	
Face Area (sq ft)	27.12		35.30	
Rows/FPI	3/16		3/16	
<b>Indoor Coil - Type</b>				
Type	Hi-Performance		Hi-Performance	
Tube Size (in.)	0.375		0.375	
Face Area (sq ft)	17.50		26.00	
Rows/FPI	3/15		3/15	
Refrigerant Control	Short Orifice <sup>10</sup>		Short Orifice <sup>9</sup>	
Drain Connection No./Size (in.)	1/1.0 NPT		1/1.0 NPT	
<b>Outdoor Fan - Type</b>				
Type	Propeller		Propeller	
No. Used/Diameter (in.)	2/26		2/26	
DriveType/No. Speeds	Direct/1		Direct/1	
CFM	10,400		11,000	
No. Motors/HP	2/.50		2/.50	
Motor RPM	1100		1100	
<b>Indoor Fan - Type</b>				
Type	FC Centrifugal		FC Centrifugal	
No. Used/Diameter (in.)	1/ 15 x 15		1/18 x 18	
DriveType/No. Speeds	Belt/1		Belt/1	
No. Motors	1		1	
Motor HP (Standard/Oversized)	3.0/5.0		3.0/5.0	
Motor RPM (Standard/Oversized)	1740/3450		1740/3450	
Motor Frame Size (Standard/Oversized)	145T/145T		145T/145T	



# General Data

## (12½, 15 Ton) High Efficiency

**Table GD-4 – Continued**

	12½Ton Downflow and Horizontal Units YC*151C3,C4,CW	15Ton Downflow and Horizontal Units YC*181C3,C4,CW
<b>Filters</b> - Type Furnished <sup>8</sup>	Throwaway	Throwaway
(No.) Size Recommended		
Downflow	(2)20 X 20 X 2/(4)20 X 25 X 2	(4)20 X 20 X 2/(4)20 X 25 X 2
Horizontal	(2)20 X 20 X 2/(4)20 X 25 X 2	(8)20 X 25 X 2
<b>Optional Hot Gas Reheat Coil</b> -Type	Hi-Performance	Hi-Performance
Tube Size (in.) OD	0.375	0.375
Face Area (sq. ft.)	175	26
Rows/FPI	1/16	1/16
<b>Refrigerant Charge</b> (Lbs of R-22) <sup>7</sup> /Circuit		
Standard	15.0/13.8 <sup>10</sup>	25.0/13.0 <sup>9</sup>
Optional Hot Gas Reheat Coil	15.3/14.3	27.8/11.4

Notes:

- Cooling Performance is rated at 95°F ambient, 80°F entering dry bulb, 67°F entering wet bulb. Gross capacity does not include the effect of fan motor heat. ARI capacity is net and includes the effect of fan motor heat. Units are suitable for operation to ±20% of nominal cfm. Certified in accordance with the Unitary Large Equipment certification program, which is based on ARI Standard 340/360-93.
- EER is rated at ARI conditions and in accordance with DOE test procedures.
- Integrated Part Load Value is rated in accordance with ARI Standard 210/240 or 360. Units are rated at 80°F ambient, 80°F entering dry bulb, and 67°F entering wet bulb at ARI rated cfm.
- Heating Performance limit settings and rating data were established and approved under laboratory test conditions using American National Standards Institute standards. Ratings shown are for elevations up to 2000 feet. For elevations above 2000 feet, ratings should be reduced at the rate of 4% for each 1000 feet above sea level.
- AFUE and Steady State Efficiency is rated in accordance with DOE test procedures.
- Sound Rating shown is tested in accordance with ARI Standard 270 or 370.
- Refrigerant charge is an approximate value. For a more precise value, see unit nameplate and service instructions.
- An optional 2 inch pleated filter is also available.
- TXV/Face-Split Option (Downflow Only) YCD181C3,4,W (EER): 11.4; (System Power kW): 15.79; (Refrigerant Control): Expansion Valve; (Refrigerant Charge): 26.0/12.0.
- TXV/Face-Split Option (Downflow Only) YCD151C3,4,W (EER): 11.3; (System Power kW): 12.92; (Refrigerant Control): Expansion Valve; (Refrigerant Charge): 13.4/12.0.

\*Indicates both downflow and horizontal units.



(17½, 20, 25 Ton)  
High Efficiency

# General Data

Table GD-5 — General Data

	17½Ton Downflow and Horizontal Units YC*211C3,C4,CW		20Ton Downflow and Horizontal Units YC*241C3,C4,CW		25Ton Units Downflow and Horizontal Units YC*301C3,C4,CW	
<b>Cooling Performance<sup>1</sup></b>						
Gross Cooling Capacity	220,000		268,000 <sup>9</sup>		300,000	
EER <sup>2</sup>	11.0		10.6		10.4	
Nominal CFM / ARI Rated CFM	7,000 / 6,200		8,000 / 7,000		10,000/8,750	
ARI Net Cooling Capacity	208,000		250,000 <sup>9</sup>		278,000	
Integrated Part Load Value <sup>3</sup>	12.0		11.2		11.0	
System Power (KW)	18.91		23.58 <sup>9</sup>		26.73	
<b>Heating Performance<sup>4</sup></b>						
Heating Models	Low	High	Low	High	Low	High
Heating Input (Btuh)	250,000	350,000	250,000	400,000	250,000	400,000
1st Stage	175,000	250,000	175,000	300,000	175,000	300,000
Heating Output (Btuh)	203,000	284,000	203,000	324,000	203,000	324,000
1st Stage	142,000	203,000	142,000	243,000	142,000	243,000
AFUE% <sup>5</sup> (Downflow/Horizontal)	80.2 / 81.0	79.3 / 79.7	80.2 / 81.0	79.8 / 79.7	80.2/81.0	79.8/79.7
Steady State Efficiency (%) <sup>5</sup>	81.0	81.0	81.0	81.0	81.0	81.0
No. Burners	1	1	1	1	1	1
No. Stages	2	2	2	2	2	2
Gas Supply Pressure (in. w.c)	2.5/14.0		2.5/14.0		2.5/14.0	
Natural or LP ((minimum/maximum)						
Gas Connection Pipe Size (in.)	1/2	3/4	1/2	3/4	1/2	3/4
<b>Compressor</b>						
No./Type	2/Scrolls		2/Scrolls		2/Scrolls	
<b>Sound Rating (BELS)<sup>6</sup></b>						
	9.4		9.4		9.4	
<b>Outdoor Coil -Type</b>						
	High-Performance		High-Performance		High Performance	
Tube Size (in.) OD	0.375		0.375		0.375	
Face Area (sq ft)	35.30		35.30 <sup>9</sup>		35.30	
Rows/FPI	3/16		3/16		3/16	
<b>Indoor Coil -Type</b>						
	High-Performance		High-Performance		High Performance	
Tube Size (in.)	0.375		0.375		0.375	
Face Area (sq ft)	26.00		26.00		26.00	
Rows/FPI	4/15		4/15		4/15	
Refrigerant Control	Short Orifice		Short Orifice <sup>9</sup>		Short Orifice	
Drain Connection No./Size (in.)	1/1.0 NPT		1/1.0 NPT		1/1.0 NPT	
<b>Outdoor Fan -Type</b>						
	Propeller		Propeller		Propeller	
No. Used/Diameter (in.)	2/26		2/26		2/26	
Drive Type/No. Speeds	Direct/1		Direct/1		Direct/1	
CFM	12,800		13,700		13,700	
No. Motors/HP	2/1.0		2/1.0		2/1.0	
Motor RPM	1125		1125		1125	
<b>Indoor Fan -Type</b>						
	FC Centrifugal		FC Centrifugal		FC Centrifugal	
No. Used/Diameter (in.)	1/18 x 18		1/18 x 18		1/18x18	
Drive Type/No. Speeds	BELT/1		BELT/1		BELT/1	
No. Motors	1		1		1	
Motor HP (Standard/Oversized)	5.0/7.5		5.0/7.5		7.5	
Motor RPM (Standard/Oversized)	3450/3470		3450/3470		3470	
Motor Frame Size (Standard/Oversized)	145T/184T		145T/184T		184T	



# (17½, 20, 25 Ton) High Efficiency

## General Data

Table GD-5 – Continued

	17½Ton Downflow and Horizontal Units YC*211C3,C4,CW	20Ton Downflow and Horizontal Units YC*241C3,C4,CW	25Ton Units Downflow and Horizontal Units YC*301C3,C4,CW
<b>Filters - Type Furnished<sup>8</sup></b>	Throwaway	Throwaway	Throwaway
(No.) Size Recommended			
Downflow	(4)20 X 20 X 2/(4)20 X 25 X 2	(4)20 X 20 X 2/(4)20 X 25 X 2	(4)20 X 20 X 2/(4)20 X 25 X 2
Horizontal	(8)20 X 25 X 2	(8)20 X 25 X 2	(8)20 X 25 X 2
<b>Optional Hot Gas Reheat Coil - Type</b>	—	Hi-Performance	—
Tube Size (in.) OD	—	0.375	—
Face Area (sq. ft.)	—	26	—
Rows/FPI	—	1/16	—
<b>Refrigerant Charge (Lbs of R-22)<sup>7</sup>/Circuit</b>			
Standard	25.7/12.5	21.8/21.8 <sup>9</sup>	24.5/24.5
Optional Hot Gas Reheat Coil	—	21.3/21.0	—

Notes:

- Cooling Performance is rated at 95°F ambient, 80°F entering dry bulb, 67°F entering wet bulb. Gross capacity does not include the effect of fan motor heat. ARI capacity is net and includes the effect of fan motor heat. Units are suitable for operation to ±20% of nominal cfm. 17½-20 tons are certified in accordance with the Unitary Large Equipment certification program, which is based on ARI Standard 340/360-93. 25 ton model ratings shown are tested in accordance with ARI Standard 340/360-93.
- EER is rated at ARI conditions and in accordance with DOE test procedures.
- Integrated Part Load Value is rated in accordance with ARI Standard 210/240 or 360. Units are rated at 80°F ambient, 80°F entering dry bulb, and 67°F entering wet bulb at ARI rated cfm.
- Heating Performance limit settings and rating data were established and approved under laboratory test conditions using American National Standards Institute standards. Ratings shown are for elevations up to 2000 feet. For elevations above 2000 feet, ratings should be reduced at the rate of 4% for each 1000 feet above sea level.
- AFUE and Steady State Efficiency is rated in accordance with DOE test procedures.
- Sound Rating shown is tested in accordance with ARI Standard 270 or 370.
- Refrigerant charge is an approximate value. For a more precise value, see unit nameplate and service instructions.
- An optional 2 inch pleated filter is also available.
- TXV/Face-Split Option (Downflow Only) YCD241C3,4,W (Gross Cooling Capacity):259,000; (ARI Net Cooling Capacity): 244,000; (System Power kW): 23.02; (Refrigerant Control): Expansion Valve; (Refrigerant Charge): 21.5/22.2

\*Indicates both downflow and horizontal units.



# Performance Data (12½ Ton) Standard Efficiency

**Table PD-1 – Gross Cooling Capacities (MBH) 12½ Ton Three Phase YC\*150D3, D4, DW, DK**

		Ambient Temperature																							
		85				95				105				115											
CFM	Enter Dry Bulb (F)	Entering Wet Bulb																							
		61		67		73		61		67		73		61		67		73							
Airflow		MBH	SHC	MBH	SHC	MBH	SHC	MBH	SHC	MBH	SHC	MBH	SHC	MBH	SHC	MBH	SHC	MBH	SHC	MBH	SHC	MBH	SHC		
4500	75	135.0	108.0	153.0	86.0	162.0	59.3	126.0	103.0	146.0	82.0	158.0	56.7	116.0	98.2	138.0	77.7	152.0	53.8	106.0	93.1	127.0	80.0	145.0	50.5
	80	136.0	128.0	154.0	105.0	163.0	79.5	127.0	123.0	147.0	101.0	159.0	76.5	117.0	117.0	138.0	97.0	153.0	73.2	110.0	110.0	128.0	92.2	145.0	69.6
	85	142.0	142.0	154.0	123.0	164.0	95.9	135.0	135.0	147.0	120.0	159.0	94.2	127.0	127.0	138.0	116.0	153.0	91.7	120.0	120.0	128.0	111.0	146.0	88.5
	90	150.0	150.0	155.0	142.0	166.0	112.0	144.0	144.0	148.0	139.0	161.0	111.0	137.0	137.0	139.0	136.0	154.0	109.0	130.0	130.0	130.0	130.0	146.0	107.0
5000	75	139.0	114.0	155.0	89.8	163.0	60.4	129.0	109.0	149.0	85.4	159.0	57.9	120.0	104.0	141.0	89.5	154.0	55.0	109.0	98.9	131.0	85.1	147.0	51.6
	80	140.0	136.0	156.0	109.0	164.0	81.3	130.0	130.0	149.0	106.0	160.0	79.1	123.0	123.0	141.0	102.0	155.0	75.8	115.0	115.0	131.0	97.5	147.0	72.2
	85	147.0	147.0	157.0	129.0	166.0	98.2	141.0	141.0	150.0	126.0	161.0	96.8	133.0	133.0	141.0	123.0	155.0	94.8	125.0	125.0	131.0	118.0	148.0	91.9
	90	155.0	155.0	158.0	148.0	167.0	115.0	149.0	149.0	151.0	147.0	163.0	115.0	143.0	143.0	143.0	143.0	157.0	114.0	135.0	135.0	135.0	135.0	149.0	111.0
5500	75	142.0	120.0	157.0	91.3	164.0	61.5	132.0	115.0	151.0	88.8	160.0	59.0	122.0	110.0	143.0	84.2	155.0	56.1	112.0	104.0	133.0	89.9	148.0	52.9
	80	143.0	143.0	158.0	112.0	165.0	82.0	135.0	135.0	152.0	110.0	161.0	80.4	127.0	127.0	143.0	107.0	156.0	78.3	119.0	119.0	134.0	102.0	149.0	74.7
	85	152.0	152.0	159.0	133.0	167.0	99.9	145.0	145.0	152.0	132.0	163.0	99.1	138.0	138.0	144.0	129.0	157.0	97.4	130.0	130.0	134.0	125.0	150.0	95.0
	90	159.0	159.0	160.0	154.0	169.0	118.0	153.0	153.0	153.0	164.0	118.0	147.0	147.0	147.0	147.0	158.0	117.0	140.0	140.0	140.0	140.0	151.0	116.0	
6000	75	145.0	125.0	158.0	93.3	165.0	62.5	135.0	120.0	153.0	91.2	161.0	60.1	125.0	115.0	145.0	87.3	156.0	57.2	115.0	110.0	136.0	82.8	149.0	54.0
	80	147.0	147.0	159.0	115.0	166.0	82.9	140.0	140.0	153.0	114.0	162.0	81.7	132.0	132.0	145.0	111.0	157.0	79.3	123.0	123.0	136.0	107.0	150.0	76.5
	85	155.0	155.0	161.0	137.0	168.0	101.1	149.0	149.0	154.0	137.0	164.0	101.0	142.0	142.0	146.0	135.0	158.0	99.8	134.0	134.0	137.0	131.0	151.0	97.8
	90	161.0	161.0	162.0	159.0	170.0	120.0	156.0	156.0	156.0	166.0	121.0	150.0	150.0	150.0	150.0	160.0	121.0	143.0	143.0	143.0	143.0	152.0	119.0	

**Notes:**

1. All capacities shown are gross and have not considered indoor fan heat. To obtain **NET** cooling capacity subtract indoor fan heat. For indoor fan heat formula, refer to appropriate airflow table notes.
2. MBH = Total Gross Cooling Capacity
3. SHC = Sensible Heat Capacity

\*Indicates both downflow and horizontal units.





# Performance Data (20, 25 Ton) Standard Efficiency

**Table PD-4 – Gross Cooling Capacities (MBH) 20 Ton Three Phase YC\*240B3, B4, BW, BK**

		Ambient Temperature (F)																							
		85			95			105			115														
CFM	Enter. Dry Bulb (F)	Entering Wet Bulb (F)																							
		61			67			73			61			67			73								
Airflow		MBH	SHC	MBH	SHC	MBH	SHC	MBH	SHC	MBH	SHC	MBH	SHC	MBH	SHC	MBH	SHC	MBH	SHC	MBH	SHC				
7200	75	223.0	180.0	251.0	143.0	265.0	97.7	209.0	173.0	242.0	137.0	260.0	94.3	195.0	165.0	228.0	130.0	252.0	90.3	180.0	158.0	212.0	135.0	241.0	85.5
	80	226.0	214.0	252.0	173.0	267.0	131.0	208.0	208.0	242.0	169.0	261.0	127.0	197.0	197.0	228.0	162.0	253.0	122.0	186.0	186.0	213.0	155.0	242.0	117.0
	85	235.0	235.0	253.0	204.0	268.0	158.0	224.0	224.0	242.0	200.0	262.0	156.0	213.0	213.0	229.0	194.0	253.0	153.0	201.0	201.0	214.0	188.0	242.0	149.0
	90	248.0	248.0	255.0	234.0	271.0	185.0	239.0	239.0	245.0	232.0	264.0	185.0	228.0	228.0	228.0	228.0	255.0	183.0	217.0	217.0	217.0	217.0	243.0	179.0
8000	75	229.0	190.0	255.0	148.0	267.0	99.4	215.0	183.0	246.0	142.0	262.0	96.1	200.0	175.0	233.0	136.0	254.0	92.2	185.0	168.0	218.0	129.0	244.0	87.1
	80	228.0	228.0	256.0	180.0	268.0	134.0	217.0	217.0	246.0	176.0	264.0	131.0	205.0	205.0	233.0	171.0	255.0	127.0	193.0	193.0	218.0	164.0	245.0	121.0
	85	243.0	243.0	257.0	212.0	271.0	162.0	233.0	233.0	247.0	210.0	265.0	161.0	222.0	222.0	234.0	206.0	257.0	158.0	210.0	210.0	220.0	199.0	245.0	155.0
	90	255.0	255.0	259.0	245.0	273.0	190.0	247.0	247.0	247.0	247.0	267.0	191.0	237.0	237.0	237.0	237.0	258.0	190.0	226.0	226.0	226.0	226.0	247.0	187.0
8800	75	234.0	199.0	257.0	151.0	268.0	101.0	220.0	192.0	249.0	147.0	263.0	97.9	205.0	184.0	237.0	141.0	256.0	93.7	190.0	177.0	222.0	134.0	246.0	88.6
	80	236.0	236.0	259.0	185.0	270.0	136.0	224.0	224.0	249.0	183.0	265.0	134.0	212.0	212.0	237.0	178.0	257.0	130.0	200.0	200.0	222.0	172.0	247.0	126.0
	85	250.0	250.0	260.0	220.0	273.0	165.0	240.0	240.0	251.0	219.0	267.0	165.0	229.0	229.0	239.0	216.0	259.0	163.0	217.0	217.0	225.0	210.0	248.0	160.0
	90	260.0	260.0	263.0	254.0	275.0	194.0	253.0	253.0	253.0	253.0	270.0	196.0	244.0	244.0	244.0	244.0	261.0	196.0	233.0	233.0	233.0	233.0	250.0	194.0
9600	75	238.0	208.0	259.0	154.0	269.0	103.0	224.0	201.0	251.0	151.0	265.0	99.6	209.0	193.0	240.0	146.0	257.0	95.1	194.0	186.0	225.0	139.0	248.0	89.2
	80	242.0	242.0	261.0	190.0	271.0	137.0	231.0	231.0	252.0	189.0	266.0	136.0	219.0	219.0	240.0	185.0	259.0	133.0	206.0	206.0	226.0	180.0	249.0	129.0
	85	254.0	254.0	263.0	227.0	274.0	167.0	246.0	246.0	254.0	227.0	269.0	168.0	236.0	236.0	243.0	225.0	261.0	167.0	224.0	224.0	229.0	220.0	251.0	165.0
	90	264.0	264.0	264.0	264.0	277.0	198.0	258.0	258.0	258.0	258.0	272.0	201.0	249.0	249.0	249.0	249.0	263.0	202.0	239.0	239.0	239.0	239.0	252.0	201.0

- Notes:
- All capacities shown are gross and have not considered indoor fan heat. To obtain **NET** cooling capacity subtract indoor fan heat. For indoor fan heat formula, refer to appropriate airflow table notes.
  - MBH = Total Gross Capacity
  - SHC = Sensible Heat Capacity

**Table PD-5 – Gross Cooling Capacities (MBH) 25 Ton Three Phase YC\*300B3, B4, BW, BK**

		Ambient Temperature (F)																							
		85			95			105			115														
CFM	Enter. Dry Bulb (F)	Entering Wet Bulb (F)																							
		61			67			73			61			67			73								
Airflow		MBH	SHC	MBH	SHC	MBH	SHC	MBH	SHC	MBH	SHC	MBH	SHC	MBH	SHC	MBH	SHC	MBH	SHC	MBH	SHC				
9000	75	266	224	299	174	319	118	247	215	285	167	309	113	228	205	266	172	297	108	209	196	244	163	280	99.9
	80	270	268	300	215	321	161	252	252	285	209	311	155	237	237	266	200	297	149	221	221	244	190	280	142
	85	286	286	301	255	323	196	272	272	286	250	312	194	256	256	267	242	298	189	240	240	246	233	281	183
	90	301	301	304	295	326	232	289	289	289	289	314	231	275	275	275	275	300	229	259	259	259	259	282	224
10000	75	272	237	303	180	322	120	253	227	290	174	312	115	234	218	271	165	300	109	214	208	249	156	284	102
	80	277	277	304	223	324	171	262	262	290	219	314	161	246	246	271	211	301	155	229	229	249	201	284	147
	85	294	294	306	266	327	208	282	282	291	263	316	200	266	266	273	257	302	197	249	249	253	248	285	192
	90	308	308	310	309	329	239	297	297	297	297	318	240	284	284	284	284	304	239	268	268	268	268	286	235
10500	75	275	243	305	183	323	122	256	233	291	177	314	117	236	223	273	188	301	111	216	214	251	178	285	103
	80	282	282	306	227	325	174	267	267	292	223	315	162	250	250	273	216	302	157	233	233	251	206	286	150
	85	298	298	308	272	328	216	286	286	294	270	317	203	270	270	276	264	304	200	253	253	256	255	286	196
	90	312	312	311	311	330	256	301	301	301	301	320	244	288	288	288	288	306	244	273	273	272	272	288	241
11000	75	278	248	306	185	324	123	258	239	293	181	315	118	239	229	275	172	302	113	217	217	253	184	286	104
	80	286	286	308	231	325	160	271	271	294	228	316	163	254	254	276	221	304	160	237	237	253	212	287	153
	85	301	301	310	277	327	224	289	289	296	276	319	205	274	274	278	271	305	204	257	257	257	257	288	200
	90	314	314	314	314	330	266	304	304	304	304	321	248	291	291	291	291	307	249	276	276	276	276	289	246

- Notes:
- All capacities shown are gross and have not considered indoor fan heat. To obtain **NET** cooling capacity subtract indoor fan heat. For indoor fan heat formula, refer to appropriate airflow table notes.
  - MBH = Total Gross Capacity
  - SHC = Sensible Heat Capacity
  - Table is for 460 volt capacity. For capacity at 230 volt, multiply table capacity by 101%.

\*Indicates both downflow and horizontal units.







# Performance Data

# (15 Ton) High Efficiency

Table PD-8— Gross Cooling Capacities (MBH) 15 Ton Three Phase YC\*181C3, C4, CW— Standard Refrigeration System

Table with columns for CFM Airflow (5400, 6000, 6600, 7200), Ambient Temperature (85, 95, 105, 115), and Entering Wet Bulb (61, 67, 73). Rows include MBH and SHC values for Dry and Wet Bulb conditions.

Notes:

- 1. All capacities shown are gross and have not considered indoor fan heat. To obtain NET cooling capacity subtract indoor fan heat. For indoor fan heat formula, refer to appropriate airflow table notes.
2. MBH = Total Gross Capacity
3. SHC = Sensible Heat Capacity

Table PD-9— Gross Cooling Capacities (MBH) 15 Ton Three Phase Y\*D181C3, C4, CW— Dehumidification (Hot Gas Reheat) or TXV Option

Table with columns for CFM Airflow (4800, 5400, 6000, 6600, 7200), Ambient Temperature (85, 95, 105, 115), and Entering Wet Bulb (61, 67, 73). Rows include MBH and SHC values for Dry and Wet Bulb conditions.

Notes:

- 1. All capacities shown are gross and have not considered indoor fan heat. To obtain NET cooling capacity subtract indoor fan heat. For indoor fan heat formula, refer to appropriate airflow table notes.
2. MBH = Total Gross Capacity
3. SHC = Sensible Heat Capacity

\*Indicates both downflow and horizontal units.







# Performance Data

# (20 Ton) High Efficiency

**Table PD-14 – Gross Cooling Capacities (MBH) 20 Ton Three Phase Y\*D241C3, C4, CW– Dehumidification (Hot Gas Reheat) Option**

		Ambient Temperature (F)																						
		85				95				105				115										
CFM	Enter. Dry Bulb (F)	Entering Wet Bulb (F)																						
		61		67		73		61		67		73		61		67		73						
Airflow		MBH	SHC	MBH	SHC	MBH	SHC	MBH	SHC	MBH	SHC	MBH	SHC	MBH	SHC	MBH	SHC	MBH	SHC	MBH	SHC			
6400	75	223.7	175.3	250.2	138.3	279.0	98.8	213.5	169.3	239.0	132.3	266.6	93.0	202.6	163.0	227.2	126.1	253.7	87.0	191.3	156.4	214.9	119.7	240.2
	80	224.9	206.3	250.6	169.7	279.2	131.4	214.8	200.3	239.4	163.6	266.8	125.3	204.2	194.1	227.7	157.5	253.9	119.2	193.2	187.7	215.2	151.0	240.5
	85	230.5	230.5	251.0	200.6	279.6	162.9	221.7	221.7	239.8	194.5	267.2	156.9	212.5	212.5	228.1	188.2	254.3	150.7	202.8	202.8	215.9	181.8	240.9
	90	243.6	243.6	252.4	231.7	280.0	194.4	234.6	234.6	241.5	225.7	267.7	188.3	225.1	225.1	230.0	219.5	254.6	181.9	215.2	215.2	215.6	215.6	241.2
7200	75	229.2	185.9	255.7	150.2	284.8	101.3	218.6	179.7	244.1	144.1	272.0	95.4	207.4	173.3	231.9	138.0	258.6	89.4	195.8	166.7	219.1	131.7	244.7
	80	231.1	220.6	256.3	179.6	285.1	137.0	220.8	214.5	244.6	173.3	272.3	130.9	208.4	208.4	232.5	167.0	258.9	124.7	199.2	197.3	219.8	160.4	245.0
	85	240.3	240.3	256.9	213.7	285.5	172.0	231.1	231.1	245.4	207.5	272.7	165.9	221.4	221.4	233.3	201.2	259.4	159.7	211.2	211.2	220.8	194.7	245.5
	90	254.0	254.0	259.2	248.5	286.0	206.7	244.5	244.5	248.0	242.5	273.2	200.5	234.5	234.5	235.0	235.0	259.8	194.1	224.0	224.0	225.1	224.1	246.0
8000	75	233.9	196.0	260.5	150.9	289.7	103.6	223.0	189.8	248.6	144.8	276.5	97.7	211.5	183.3	236.1	138.4	262.7	91.4	199.6	176.7	223.0	131.9	248.4
	80	234.8	234.8	261.0	188.8	290.0	142.4	225.4	225.4	249.0	182.5	276.9	136.2	215.6	215.6	236.5	176.1	263.1	129.9	205.3	205.3	223.5	169.5	248.8
	85	249.0	249.0	262.0	226.4	290.5	180.8	239.3	239.3	250.1	220.2	277.4	174.6	229.2	229.2	237.8	213.8	263.6	168.3	218.6	218.6	225.1	207.3	249.2
	90	263.3	263.3	263.7	263.7	291.0	218.5	253.3	253.3	254.6	253.1	277.9	212.2	242.9	242.9	243.3	243.3	264.2	205.8	231.9	231.9	232.3	232.3	249.9
8800	75	237.9	205.8	264.5	156.8	293.8	105.7	226.7	199.5	252.2	150.6	280.3	99.6	215.1	193.0	239.4	144.2	266.1	93.2	202.9	186.3	226.0	137.6	251.5
	80	242.3	242.3	265.0	197.7	294.1	147.5	232.1	232.1	252.7	191.4	280.6	141.3	221.9	221.9	239.9	184.9	266.6	135.0	211.2	211.2	226.6	178.2	251.9
	85	256.5	256.5	266.4	238.7	294.7	189.2	246.5	246.5	254.3	232.4	281.0	182.8	235.9	235.9	241.8	226.0	267.0	176.3	224.9	224.9	228.9	219.4	252.4
	90	271.4	271.4	271.8	271.8	295.2	229.9	261.0	261.0	261.4	261.4	281.8	223.6	250.1	250.1	250.5	250.5	267.9	217.2	238.7	238.7	239.1	239.1	253.4
9600	75	241.4	215.2	267.8	162.4	297.1	107.4	230.0	208.9	255.3	156.2	283.4	101.2	218.2	202.3	242.2	149.7	269.0	94.8	205.9	195.6	228.4	143.0	254.0
	80	248.0	248.0	268.4	206.4	297.6	152.5	237.9	237.9	255.9	200.0	283.8	146.2	227.5	227.5	242.8	193.4	269.5	139.8	216.4	216.4	229.3	186.7	254.6
	85	263.1	263.1	270.3	250.7	298.0	197.1	252.8	252.8	258.1	244.3	284.3	190.7	241.9	241.9	245.5	237.9	270.0	184.1	230.5	230.5	230.7	230.7	255.1
	90	278.6	278.6	278.9	278.9	298.9	241.1	267.9	267.9	268.3	268.3	285.3	234.7	256.6	256.6	257.0	257.0	271.1	228.2	244.7	244.7	245.1	245.1	256.4

**Notes:**

- All capacities shown are gross and have not considered indoor fan heat. To obtain **NET** cooling capacity subtract indoor fan heat. For indoor fan heat formula, refer to appropriate airflow table notes.
- MBH = Total Gross Capacity
- SHC = Sensible Heat Capacity



# Performance Data

# (25 Ton) High Efficiency

**Table PD-15 — Gross Cooling Capacities (MBH)25 Ton Three PhaseYC\*301C3, C4, CW— Standard Refrigeration System**

CFM Airflow		Ambient Temperature (F)																							
		85						95						105						115					
		Enter. Dry Bulb		61		67		73		61		67		73		61		67		73		61		67	
Entering Wet Bulb (F)		MBH	SHC	MBH	SHC	MBH	SHC	MBH	SHC	MBH	SHC	MBH	SHC	MBH	SHC	MBH	SHC	MBH	SHC	MBH	SHC	MBH	SHC	MBH	SHC
9000	75	277	243	306	187	316	117	258	234	295	178	314	115	238	224	276	169	305	110	218	214	253	163	292	104
	80	284	284	307	225	321	169	269	269	295	225	317	161	252	252	277	217	307	158	235	235	254	207	293	151
	85	300	300	309	269	325	198	289	289	298	271	320	202	273	273	280	266	308	201	256	256	259	256	293	198
	90	312	312	313	312	329	236	305	305	305	305	321	240	293	293	293	293	310	245	277	277	277	277	295	244
10000	75	284	258	310	188	319	121	264	249	299	185	316	117	244	239	282	178	308	112	224	224	259	168	295	106
	80	294	294	310	233	323	175	280	280	300	236	319	170	263	263	283	230	309	163	245	245	260	221	296	158
	85	307	307	313	280	327	202	298	298	303	286	322	207	284	284	287	284	312	208	267	267	267	267	297	208
	90	318	318	318	318	331	241	312	312	312	312	324	248	301	301	301	301	314	255	287	287	287	287	299	257
10500	75	286	265	311	190	320	122	267	256	300	189	316	118	247	246	284	182	309	113	228	228	261	172	296	107
	80	297	297	312	237	324	178	285	285	302	241	320	174	267	267	285	237	310	165	249	249	262	227	298	162
	85	310	310	315	285	328	204	302	302	305	293	323	210	289	289	289	289	313	212	272	272	272	272	299	213
	90	320	320	320	320	332	244	314	314	314	314	325	251	305	305	305	305	316	260	292	292	292	292	301	264
11000	75	289	272	312	192	321	123	270	264	302	192	317	119	249	249	286	186	309	114	231	231	263	176	297	108
	80	300	300	313	240	324	181	289	289	304	246	321	177	272	272	287	243	311	170	253	253	265	234	299	165
	85	312	312	316	289	329	205	305	305	307	299	324	212	293	293	293	293	314	215	276	276	276	276	300	217
	90	322	322	321	321	332	246	317	317	317	317	326	255	308	308	308	308	317	265	295	295	295	295	303	270

Notes:

1. All capacities shown are gross and have not considered indoor fan heat. To obtain **NET** cooling capacity subtract indoor fan heat. For indoor fan heat formula, refer to appropriate airflow table notes.
2. MBH = Total Gross Capacity
3. SHC = Sensible Heat Capacity

•Indicates both downflow and horizontal units.



# Performance Data

# (25 Ton) High Efficiency

**Table PD-16 – Gross Cooling Capacities (MBH)25 Ton Three PhaseYC\*301C3, C4, CW– TXV Option**

		Ambient Temperature (F)																							
		85			95			105			115														
		Enter. Dry Bulb		61		67		73		Entering Wet Bulb (F)		61		67		73									
CFM	Airflow (F)	MBH	SHC	MBH	SHC	MBH	SHC	MBH	SHC	MBH	SHC	MBH	SHC	MBH	SHC	MBH	SHC								
8000	75	267.9	224.2	297.7	171.5	330.7	118.0	254.9	216.9	283.7	164.4	315.3	111.1	241.5	209.3	269.2	157.1	299.2	104.0	227.5	201.6	254.0	149.6	282.7	96.8
	80	268.8	268.8	298.0	214.0	330.9	161.1	259.3	255.4	284.1	206.8	315.5	154.0	246.8	246.7	269.6	199.5	299.5	146.7	234.0	234.0	254.5	191.9	283.0	139.4
	85	284.5	284.5	299.2	256.4	331.2	203.2	273.2	273.2	285.4	249.2	315.9	196.1	261.3	261.3	271.0	241.8	299.8	188.8	248.9	248.9	256.2	234.3	283.3	181.4
	90	300.3	300.3	300.2	300.2	331.6	245.2	288.7	288.7	290.5	286.0	316.4	238.0	276.5	276.5	276.4	276.4	300.4	230.6	263.8	263.8	263.7	263.7	284.0	223.1
9000	75	273.6	238.6	303.4	180.1	336.6	120.9	260.4	231.2	289.0	172.8	320.7	114.0	246.7	223.6	273.9	170.7	304.2	106.8	232.5	215.9	258.3	163.2	287.1	99.6
	80	279.6	279.5	303.8	227.0	336.8	168.4	267.3	267.3	289.5	219.8	321.0	161.3	255.2	255.2	274.6	212.4	304.5	154.0	242.6	242.6	259.1	204.8	287.5	146.5
	85	295.1	295.1	305.6	274.3	337.2	215.2	283.4	283.4	291.5	267.1	321.4	208.1	271.0	271.0	276.9	259.7	304.9	200.7	258.0	258.0	261.9	252.2	287.8	193.1
	90	311.9	311.9	311.8	311.8	338.0	261.8	299.6	299.6	299.6	299.6	322.2	254.5	286.9	286.9	286.8	286.8	305.9	247.1	273.5	273.5	273.5	273.5	288.9	239.4
10000	75	278.6	252.6	308.1	188.2	341.5	123.5	265.2	245.2	293.3	180.9	325.3	116.5	251.3	237.6	278.0	173.5	308.4	109.2	234.1	234.1	262.1	165.9	290.8	101.7
	80	287.6	287.6	308.7	239.7	341.8	175.5	275.5	275.5	294.0	232.5	325.6	168.3	263.1	263.1	278.8	225.0	308.7	160.9	250.0	250.0	263.1	217.3	291.2	153.4
	85	304.6	304.6	311.3	291.9	342.1	226.8	292.3	292.3	297.0	284.7	325.9	219.5	279.4	279.4	279.3	279.3	309.1	212.1	266.0	266.0	267.7	262.9	291.7	204.4
	90	322.2	322.2	322.1	322.1	343.3	277.9	309.3	309.3	309.3	309.3	327.2	270.5	295.9	295.9	295.9	295.9	310.6	263.1	282.0	282.0	282.0	282.0	293.3	255.3
11000	75	283.1	266.2	312.0	196.0	345.5	125.9	269.5	258.8	296.9	188.7	329.1	118.9	253.1	253.1	281.2	181.2	311.8	111.5	241.4	237.4	265.1	173.5	293.9	104.0
	80	295.1	295.1	312.9	252.1	345.8	182.3	282.8	282.8	297.9	244.7	329.4	175.0	269.9	269.9	282.4	237.2	312.2	167.7	256.4	256.4	266.5	229.4	294.3	160.1
	85	312.9	312.9	312.8	312.8	346.2	237.9	300.0	300.0	299.9	299.9	329.9	230.6	286.7	286.7	288.1	285.2	312.8	223.1	272.8	272.8	272.7	272.7	295.0	215.4
	90	331.2	331.2	331.1	331.1	347.8	293.5	317.8	317.8	317.8	317.8	331.6	286.2	304.0	304.0	303.8	303.8	314.7	278.6	289.3	289.3	289.3	289.3	297.3	271.0
12000	75	283.8	283.8	315.3	203.6	348.9	128.2	271.5	271.5	299.9	196.2	332.2	121.1	259.9	256.8	284.1	188.6	314.7	113.8	245.2	245.2	267.7	180.9	296.5	106.2
	80	301.8	301.8	316.6	264.1	349.2	188.9	289.0	289.0	301.2	256.6	332.6	181.7	275.9	275.9	285.7	249.1	315.2	174.3	262.0	262.0	269.5	241.3	297.0	166.6
	85	320.3	320.3	322.4	316.7	349.8	248.8	307.0	307.0	308.0	306.9	333.2	241.5	293.2	293.2	293.1	293.1	315.8	233.9	278.8	278.8	278.8	278.8	297.8	226.2
	90	339.1	339.1	339.0	339.0	351.7	308.8	325.4	325.4	325.3	325.3	335.6	301.5	310.9	310.9	310.9	310.9	318.5	294.0	295.9	295.9	295.9	295.9	301.0	286.4

**Notes:**

- All capacities shown are gross and have not considered indoor fan heat. To obtain **NET** cooling capacity subtract indoor fan heat. For indoor fan heat formula, refer to appropriate airflow table notes.
- MBH = Total Gross Capacity
- SHC = Sensible Heat Capacity

\*Indicates both downflow and horizontal units.



# Performance Data (12½ Ton) Standard Efficiency

**Table PD-17 — Evaporator Fan Performance — 12½ Ton — YC\*150D**

CFM	External Static Pressure (Inches of Water)																			
	.10		.20		.30		.40		.50		.60		.70		.80		.90		1.00	
	RPM	BHP	RPM	BHP	RPM	BHP	RPM	BHP	RPM	BHP	RPM	BHP	RPM	BHP	RPM	BHP	RPM	BHP	RPM	BHP
4000	—	—	—	—	—	—	581	0.97	614	1.08	646	1.20	677	1.31	707	1.41	738	1.52	768	1.63
4500	—	—	—	—	588	1.15	622	1.27	652	1.38	682	1.50	711	1.63	738	1.76	766	1.88	793	2.00
5000	571	1.26	602	1.37	631	1.46	663	1.63	693	1.75	720	1.87	747	2.00	773	2.15	798	2.29	823	2.43
5500	621	1.65	650	1.79	678	1.87	704	2.01	734	2.19	760	2.33	786	2.45	810	2.59	834	2.74	858	2.91
6000	674	2.10	699	2.28	727	2.37	749	2.48	775	2.66	802	2.86	826	3.00	849	3.13	872	3.28	894	3.44

**3 HP Standard Motor & Field Supplied Low Static Drive (1)**

**Table PD-17 — Evaporator Fan Performance — 12½ Ton — YC\*150D — Continued**

CFM	External Static Pressure (Inches of Water)																			
	1.10		1.20		1.30		1.40		1.50		1.60		1.70		1.80		1.90		2.00	
	RPM	BHP	RPM	BHP	RPM	BHP	RPM	BHP	RPM	BHP	RPM	BHP	RPM	BHP	RPM	BHP	RPM	BHP	RPM	BHP
4000	799	1.75	829	1.87	856	1.99	884	2.11	911	2.24	937	2.35	962	2.47	987	2.59	1010	2.70	1034	2.82
4500	820	2.12	847	2.24	873	2.36	900	2.50	927	2.64	952	2.77	978	2.91	1003	3.05	1025	3.18	1049	3.32
5000	847	2.56	873	2.70	897	2.83	921	2.96	945	3.09	970	3.24	993	3.38	1017	3.53	1041	3.69	1064	3.85
5500	881	3.06	903	3.22	926	3.37	948	3.52	971	3.67	993	3.80	1015	3.95	1036	4.09	1058	4.25	1081	4.41
6000	916	3.61	938	3.78	959	3.96	980	4.13	1001	4.31	1021	4.46	1042	4.62	1062	4.78	1082	4.93	1103	5.09

**5 HP Oversized Motor & Drive (3)**

**5 HP Oversized Motor & Drive (3)**

**5 HP Oversized Motor & Field Supplied High Static Drive (3)**

For Standard Evaporator Fan Speed (RPM), reference Table PD-31.  
 For Oversize Evaporator Fan Speed (RPM), reference Table PD-33.  
 Data includes pressure drop due to filters and wet coils.

No accessories or options are included in pressure drop data.  
 Refer to Table PD-36 to determine add'l static pressure drop due to other options/accessories

Fan motor heat (MBH) = 3.15 x Fan Bhp.

Notes:

1. Field Supplied Fan Sheave BK90 Required. Field Supplied Belt may be necessary.
2. 3 HP Standard Motor with Field Supplied Motor Sheave 1VP44 Required. Field Supplied Belt may be necessary.
3. 5 HP Oversize Motor with Field Supplied Motor Sheave 1VP50 Required. Field Supplied Belt may be necessary.
4. For 380V/60 Hz units, the oversized motor is used as the standard motor. Refer to "Motor and Sheave/Fan Speed" tables to determine operating range.

Factory supplied motors, in commercial equipment, are definite purpose motors, specifically designed and tested to operate reliably and continuously at all cataloged conditions. Using the full horsepower range of our fan motors as shown in our tabular data will not result in nuisance tripping or premature motor failure. Our product's warranty will not be affected.



# Performance Data (15 Ton) Standard Efficiency

**Table PD-18 — Evaporator Fan Performance — 15 Ton — YC\*180B**

CFM	External Static Pressure (Inches of Water)																				
	.10		.20		.30		.40		.50		.60		.70		.80		.90		1.00		
RPM	BHP	RPM	BHP	RPM	BHP	RPM	BHP	RPM	BHP	RPM	BHP	RPM	BHP	RPM	BHP	RPM	BHP	RPM	BHP	RPM	BHP
<b>3 HP Standard Motor &amp; Field Supplied Low Static Drive (1)</b>										<b>3 HP Standard Motor &amp; Drive</b>											
4800	—	—	584	1.22	613	1.33	647	1.49	676	1.59	704	1.71	732	1.84	759	1.98	485	2.13	811	2.26	
5200	591	1.41	623	1.53	649	1.61	679	1.78	709	1.93	736	2.04	762	2.17	788	2.31	831	2.46	837	2.62	
5600	633	1.76	661	1.89	688	1.96	713	2.09	742	2.29	769	2.43	793	2.55	817	2.69	542	2.84	865	3.00	
6000	674	2.10	699	2.28	727	2.37	749	2.48	775	2.66	802	2.86	826	3.00	849	3.13	872	3.28	894	3.44	
6400	716	2.52	739	2.73	766	2.85	788	2.94	809	3.08	835	3.30	860	3.50	882	3.65	903	3.79	925	3.94	
6800	758	3.00	779	3.22	804	3.38	827	3.47	847	3.58	868	3.77	892	4.01	915	4.21	936	4.37	957	4.52	
7200	800	3.54	820	3.76	842	3.96	866	4.07	885	4.17	904	4.32	925	4.54	948	4.81	970	5.01	990	5.17	
<b>5 HP Oversized Motor &amp; Drive</b>																					

**Table PD-18 — Evaporator Fan Performance — 15 Ton — YC\*180B — Continued**

CFM	External Static Pressure (Inches of Water)																				
	1.10		1.20		1.30		1.40		1.50		1.60		1.70		1.80		1.90		2.00		
RPM	BHP	RPM	BHP	RPM	BHP	RPM	BHP	RPM	BHP	RPM	BHP	RPM	BHP	RPM	BHP	RPM	BHP	RPM	BHP	RPM	BHP
<b>3 HP Standard Motor &amp; Drive</b>										<b>3 HP Standard Motor &amp; High Static Drive Accessory</b>											
4800	836	2.38	862	2.51	887	2.64	912	2.77	937	2.90	962	3.04	987	3.19	1011	3.34	1034	3.49	1057	3.65	
5200	861	2.76	885	2.90	908	3.04	932	3.18	955	3.31	978	3.46	1002	3.60	1025	3.75	1047	3.90	1070	4.06	
5600	888	3.17	910	3.33	932	3.49	954	3.64	976	3.79	998	3.93	1020	4.08	1042	4.23	1063	4.38	1085	4.54	
6000	916	3.61	938	3.78	959	3.96	980	4.13	1001	4.31	1021	4.46	1042	4.62	1062	4.78	1082	4.93	1103	5.09	
6400	946	4.10	967	4.28	987	4.47	1007	4.66	1027	4.85	1047	5.03	1066	5.21	1085	5.38	1104	5.55	—	—	
6800	977	4.67	997	4.84	1017	5.03	1036	5.22	1055	5.42	1074	5.62	—	—	—	—	—	—	—	—	
7200	1009	5.33	1028	5.49	1047	5.67	—	—	—	—	—	—	—	—	—	—	—	—	—	—	
<b>5 HP Oversized Motor &amp; Drive</b>																					

**5 HP Oversized Motor & Field Supplied High Static Drive (2)**

For Standard Evaporator Fan Speed (RPM), reference Table PD-31.  
 For Standard Motor & High Static Drive Accessory Fan Speed (RPM), reference Table PD-32.  
 For Oversize Evaporator Fan Speed (RPM), reference Table PD-33.  
 Fan motor heat (MBH) = 3.15 x Fan Bhp.  
 Data includes pressure Drop Due to Wet Coils and Filters.  
 No accessories or options are included in pressure drop data.  
 Refer to Table PD-36 to determine add'l static pressure drop due to other options/accessories

Notes:  
 1. Field Supplied Fan Sheave BK105 Required. Field Supplied Belt may be necessary.  
 2. 5 HP Oversize Motor with Field Supplied Motor Sheave 1VP50 required. Field Supplied Belt may be necessary.  
 3. For 380V/60 Hz units, the oversized motor is used as the standard motor. Refer to "Motor and Sheave/Fan Speed" tables to determine operating range.

Factory supplied motors, in commercial equipment, are definite purpose motors, specifically designed and tested to operate reliably and continuously at all cataloged conditions. Using the full horsepower range of our fan motors as shown in our tabular data will not result in nuisance tripping or premature motor failure. Our product's warranty will not be affected.

\*Indicates both downflow and horizontal units.





# Performance Data (17½ Ton) Standard Efficiency

**Table PD-19 — Evaporator Fan Performance — 17½ Ton — YC\*210C**

CFM	External Static Pressure (Inches of Water)																			
	.10		.20		.30		.40		.50		.60		.70		.80		.90		1.00	
	RPM	BHP	RPM	BHP	RPM	BHP	RPM	BHP	RPM	BHP	RPM	BHP	RPM	BHP	RPM	BHP	RPM	BHP	RPM	BHP
<b>5 HP Standard Motor &amp; Low Static Drive Accessory</b>																				
5600	—	—	720	2.27	744	2.39	767	2.51	791	2.65	815	2.79	838	2.93	860	3.08	883	3.23	906	3.39
6300	776	3.02	798	3.16	820	3.29	841	3.42	862	3.56	883	3.72	905	3.88	926	4.04	946	4.20	965	4.36
7000	857	4.11	878	4.26	898	4.41	917	4.56	935	4.70	954	4.86	974	5.03	993	5.21	1013	5.39	1031	5.57
7700	939	5.44	958	5.60	976	5.77	994	5.93	1011	6.09	1028	6.25	1045	6.42	1062	6.60	1080	6.79	1098	6.99
8400	1021	7.03	1038	7.21	1055	7.39	1072	7.57	1088	7.74	1104	7.92	1119	8.09	1135	8.27	1151	8.46	—	—

**7.5 HP Oversized Motor & Drive**

**5 HP Standard Motor & Drive**

**Table PD-19 — Evaporator Fan Performance — 17½ Ton— YC\*210C — Continued**

CFM	External Static Pressure (Inches of Water)																			
	1.10		1.20		1.30		1.40		1.50		1.60		1.70		1.80		1.90		2.00	
	RPM	BHP	RPM	BHP	RPM	BHP	RPM	BHP	RPM	BHP	RPM	BHP	RPM	BHP	RPM	BHP	RPM	BHP	RPM	BHP
<b>5 HP Standard Motor &amp; Drive</b>																				
5600	929	3.55	951	3.72	974	3.90	996	4.08	1018	4.27	1039	4.45	1060	4.62	1082	4.81	1105	5.01	1127	5.22
6300	984	4.53	1005	4.70	1026	4.88	1047	5.07	1067	5.27	1087	5.46	1106	5.66	1125	5.86	1145	6.07	1164	6.27
7000	1049	5.74	1066	5.92	1084	6.11	1102	6.30	1121	6.49	1139	6.69	1159	6.90	1176	7.11	1194	7.33	1212	7.55
7700	1116	7.20	1132	7.39	1149	7.59	1164	7.78	1180	7.98	1197	8.18	1213	8.39	1230	8.60	—	—	—	—
8400	—	—	—	—	—	—	—	—	—	—	—	—	—	—	—	—	—	—	—	—

**7.5 HP Oversized Motor & Drive**

For Standard Evaporator Fan Speed (RPM), reference Table PD-31.  
 For Oversize Evaporator Fan Speed (RPM), reference Table PD-33.  
 For Standard Motor and Low Static Drive, reference Table PD-34.  
 Fan motor heat (MBH) = 3.15 x Fan Bhp.  
 Data includes pressure Drop Due to West Coils and Filters.  
 No accessories or options are included in pressure drop data.  
 Refer to Table PD-36 to determine add'l static pressure drop due to other options/accessories

Notes:  
 1. For 380V/60 Hz units, the oversized motor is used as the standard motor, Refer to "Motor and Sheave/Fan Speed" tables to determine operating range.

Factory supplied motors, in commercial equipment, are definite purpose motors, specifically designed and tested to operate reliably and continuously at all cataloged conditions. Using the full horsepower range of our fan motors as shown in our tabular data will not result in nuisance tripping or premature motor failure. Our product's warranty will not be affected.

\*Indicates both downflow and horizontal units.



# Performance Data (20 Ton) Standard Efficiency

**Table PD-20 — Evaporator Fan Performance — 20 Ton — YC\*240B**

CFM	External Static Pressure (Inches of Water)																			
	.10		.20		.30		.40		.50		.60		.70		.80		.90		1.00	
	RPM	BHP	RPM	BHP	RPM	BHP	RPM	BHP	RPM	BHP	RPM	BHP	RPM	BHP	RPM	BHP	RPM	BHP	RPM	BHP
<b>5 HP Standard Motor &amp; Field Supplied Low Static Drive (1)</b>										<b>5 HP Standard Motor &amp; Drive</b>										
6400	511	1.56	538	1.72	564	1.99	590	2.16	615	2.31	639	2.47	663	2.65	688	2.84	711	3.04	735	3.23
7200	555	2.25	587	2.46	614	2.67	640	2.88	663	3.06	685	3.23	706	3.41	728	3.60	749	3.80	771	4.01
8000	609	3.03	639	3.26	665	3.50	690	3.73	712	3.96	733	4.16	753	4.35	772	4.55	792	4.75	811	4.96
8800	664	3.98	692	4.23	717	4.49	740	4.75	762	5.01	782	5.25	801	5.48	820	5.69	838	5.90	855	6.12
9600	719	5.11	745	5.38	770	5.66	792	5.94	813	6.23	832	6.51	851	6.78	869	7.03	886	7.27	902	7.50
										<b>7.5 HP Oversized Motor &amp; Drive</b>										

**Table PD-20 — Evaporator Fan Performance — 20 Ton— YC\*240B — Continued**

CFM	External Static Pressure (Inches of Water)																			
	1.10		1.20		1.30		1.40		1.50		1.60		1.70		1.80		1.90		2.00	
	RPM	BHP	RPM	BHP	RPM	BHP	RPM	BHP	RPM	BHP	RPM	BHP	RPM	BHP	RPM	BHP	RPM	BHP	RPM	BHP
<b>5 HP Standard Motor &amp; Drive</b>								<b>5 HP Standard Motor &amp; High Static Drive Accessory</b>												
6400	758	3.4	781	3.64	804	3.85	827	4.07	848	4.29	869	4.51	890	4.73	910	4.97	929	5.21	949	5.45
7200	792	4.24	813	4.46	834	4.68	854	4.90	875	5.13	895	5.37	916	5.62	936	5.86	955	6.11	973	6.35
8000	830	5.18	850	5.42	869	5.66	888	5.91	907	6.16	925	6.40	944	6.65	962	6.90	981	7.16	1000	7.44
8800	873	6.34	890	6.58	908	6.82	925	7.08	943	7.34	961	7.61	978	7.88	995	8.16	—	—	—	—
9600	919	7.73	935	7.97	951	8.21	967	8.46	—	—	—	—	—	—	—	—	—	—	—	—
								<b>7.5 HP Oversized Motor &amp; Drive</b>												

For Standard Evaporator Fan Speed (RPM), reference Table PD-31.  
 For Standard Motor and High Static Drive Accessory/Fan Speed (RPM), reference Table PD-32.  
 For Oversize Evaporator Fan Speed (RPM), reference Table PD-33.  
 Fan motor heat (MBH) = 3.15 x Fan Bhp.  
 Data includes pressure Drop Due to West Coils and Filters.  
 No accessories or options are included in pressure drop data.  
 Refer to Table PD-36 to determine add'l static pressure drop due to other options/accessories

- Notes:
1. Field Supplied Fan Sheave BK190 Required. Field Supplied Belt may be necessary.
  2. 7.5 HP Oversize Motor with Field Supplied Motor Sheave 1VP50 Required. Field Supplied Belt may be necessary.
  3. For 380V/60 Hz units, the oversized motor is used as the standard motor, Refer to "Motor and Sheave/Fan Speed" tables to determine operating range.

Factory supplied motors, in commercial equipment, are definite purpose motors, specifically designed and tested to operate reliably and continuously at all cataloged conditions. Using the full horsepower range of our fan motors as shown in our tabular data will not result in nuisance tripping or premature motor failure. Our product's warranty will not be affected.

\*Indicates both downflow and horizontal units.



# Performance Data (25 Ton) Standard Efficiency

**Table PD-21— Evaporator Fan Performance — 25 Ton — YC\*300B**

CFM	External Static Pressure (Inches of Water)																			
	.10		.20		.30		.40		.50		.60		.70		.80		.90		1.00	
	RPM	BHP	RPM	BHP	RPM	BHP	RPM	BHP	RPM	BHP	RPM	BHP	RPM	BHP	RPM	BHP	RPM	BHP	RPM	BHP
	<b>7.5 HP Standard Motor &amp; Low Static Drive Accessory</b>										<b>7.5 HP Standard Motor &amp; Drive</b>									
7000	—	—	—	—	614	2.59	639	2.77	662	2.94	684	3.11	706	3.30	728	3.49	750	3.70	773	3.92
7500	—	—	621	2.85	647	3.08	671	3.29	693	3.48	715	3.66	736	3.85	756	4.05	777	4.26	797	4.47
8000	627	3.16	655	3.39	680	3.64	704	3.87	725	4.09	746	4.28	766	4.48	785	4.68	805	4.89	824	5.11
8500	662	3.76	689	4.00	714	4.26	737	4.52	758	4.76	778	4.98	797	5.18	815	5.39	834	5.61	852	5.83
9000	698	4.43	724	4.69	747	4.96	770	5.24	790	5.50	810	5.74	828	5.97	846	6.18	864	6.41	881	6.63
9500	734	5.18	758	5.45	781	5.73	803	6.02	823	6.31	842	6.58	860	6.83	878	7.06	895	7.29	911	7.53
10000	770	6.00	793	6.29	816	6.59	837	6.89	856	7.20	875	7.49	893	7.77	910	8.02	926	8.27	942	8.51
10500	806	6.92	829	7.22	850	7.53	870	7.85	890	8.17	908	8.48	—	—	—	—	—	—	—	—
11000	842	7.92	864	8.24	885	8.56	—	—	—	—	—	—	—	—	—	—	—	—	—	—

**7.5 HP Standard Motor & High Static Drive Accessory**

**Table PD-21 — Evaporator Fan Performance — 25 Ton — YC\*300B — Continued**

CFM	External Static Pressure (Inches of Water)									
	1.10		1.20		1.30		1.40		1.50	
	RPM	BHP	RPM	BHP	RPM	BHP	RPM	BHP	RPM	BHP
	<b>7.5 HP Standard Motor &amp; Drive</b>									
7000	795	4.14	816	4.36	837	4.58	858	4.80	879	5.03
7500	818	4.70	839	4.94	859	5.18	879	5.41	899	5.65
8000	843	5.34	862	5.58	882	5.83	901	6.09	920	6.34
8500	870	6.06	888	6.30	906	6.55	924	6.81	943	7.08
9000	898	6.87	916	7.11	933	7.36	950	7.62	967	7.89
9500	928	7.77	944	8.01	960	8.27	977	8.53	—	—
10000	—	—	—	—	—	—	—	—	—	—
10500	—	—	—	—	—	—	—	—	—	—
11000	—	—	—	—	—	—	—	—	—	—

**7.5 HP Standard Motor & High Static Drive Accessory**

For Standard Evaporator Fan Speed (RPM), reference Table PD-31.  
 For Standard Motor and High Static Drive, reference Table PD-32.  
 For Standard Motor and Low Static Drive, reference Table PD-34.  
 Data includes pressure drop due to filters and wet coils.  
 No accessories or options are included in pressure drop data.  
 Refer to Table PD-36 to determine add'l static pressure drop due to other options/accessories  
 Fan motor heat (MBH) = 3.15 x Fan Bhp

Notes:

- For 380V/60 Hz units, the oversized motor is used as the standard motor. Refer to "Motor and Sheave/Fan Speed" tables to determine operating range.

Factory supplied motors, in commercial equipment, are definite purpose motors, specifically designed and tested to operate reliably and continuously at all cataloged conditions. Using the full horsepower range of our fan motors as shown in our tabular data will not result in nuisance tripping or premature motor failure. Our product's warranty will not be affected.

\*Indicates both downflow and horizontal units.



# Performance Data

# (12½ Ton) High Efficiency

**Table PD-22— Evaporator Fan Performance — 12½ Ton — YCD151C— Standard or TXV Refrigeration System**

CFM	External Static Pressure (Inches of Water)																				
	.10		.20		.30		.40		.50		.60		.70		.80		.90		1.00		
RPM	BHP	RPM	BHP	RPM	BHP	RPM	BHP	RPM	BHP	RPM	BHP	RPM	BHP	RPM	BHP	RPM	BHP	RPM	BHP	RPM	BHP
<b>3 HP Standard Motor &amp; Field Supplied Low Static Drive (1)</b>									<b>3 HP Standard Motor &amp; Drive</b>												
4000	—	—	497	0.75	551	0.92	598	1.08	641	1.23	680	1.38	716	1.53	750	1.67	782	1.82	812	1.96	
4500	—	—	531	0.96	583	1.16	629	1.34	671	1.52	709	1.70	745	1.87	778	2.03	810	2.20	840	2.36	
5000	506	0.98	565	1.21	616	1.43	661	1.65	701	1.85	739	2.05	774	2.25	807	2.44	838	2.63	868	2.81	
5500	544	1.24	600	1.51	649	1.76	693	2.00	733	2.23	770	2.45	804	2.67	837	2.89	868	3.10	897	3.31	
6000	582	1.55	636	1.84	684	2.12	726	2.39	765	2.65	801	2.90	835	3.15	867	3.39	898	3.63	927	3.86	
<b>3 HP Standard Motor &amp; High Static Drive Accessory</b>													<b>5 HP Oversized Motor &amp; Drive</b>								

**Table PD-22 — Evaporator Fan Performance — 12½ Ton— YCD151C — Continued**

CFM	External Static Pressure (Inches of Water)																				
	1.10		1.20		1.30		1.40		1.50		1.60		1.70		1.80		1.90		2.00		
RPM	BHP	RPM	BHP	RPM	BHP	RPM	BHP	RPM	BHP	RPM	BHP	RPM	BHP	RPM	BHP	RPM	BHP	RPM	BHP	RPM	BHP
<b>3 HP Standard Motor &amp; Drive</b>			<b>3 HP Standard Motor &amp; High Static Drive Accessory</b>																		
4000	841	2.09	869	2.23	896	2.36	922	2.50	947	2.63	971	2.76	994	2.89	1016	3.04	1037	3.19	1059	3.35	
4500	869	2.52	896	2.68	923	2.84	948	2.99	973	3.14	997	3.30	1020	3.45	1043	3.60	1065	3.75	1087	3.89	
5000	897	2.99	924	3.17	950	3.35	976	3.53	1000	3.71	1024	3.88	1047	4.05	1070	4.22	1092	4.39	1113	4.56	
5500	925	3.52	952	3.72	978	3.92	1004	4.12	1028	4.32	1052	4.51	1075	4.71	1097	4.90	1119	5.09	1140	5.28	
6000	955	4.09	981	4.32	1007	4.54	1032	4.77	1056	4.99	1080	5.21	1103	5.42	1125	5.64	—	—	—	—	
<b>5 HP Oversized Motor &amp; Drive</b>																					

For Standard Evaporator Fan Speed (RPM), reference Table PD-31.  
 For Standard Motor & High Static Drive Accessory/Fan Speed (RPM), reference Table PD-32.  
 For Oversize Evaporator Fan Speed (RPM), reference Table PD-33.  
 Data includes pressure drop due to filters and wet coils.  
 No accessories or options are included in pressure drop data.  
 Refer to Table PD-36 to determine add'l static pressure drop due to other options/accessories  
 Fan motor heat (MBH) = 3.15 x Fan Bhp.

Factory supplied motors, in commercial equipment, are definite purpose motors, specifically designed and tested to operate reliably and continuously at all cataloged conditions. Using the full horsepower range of our fan motors as shown in our tabular data will not result in nuisance tripping or premature motor failure. Our product's warranty will not be affected.

Notes:  
 1. Field Supplied Fan Sheave BK115 required. Field Supplied Belt may be necessary.

**Table PD-23 — Evaporator Fan Performance — 12½ Ton — Y\*D151C — Dehumidification (Hot Gas Reheat) Option**

CFM	External Static Pressure (Inches of Water)																				
	.10		.20		.30		.40		.50		.60		.70		.80		.90		1.00		
RPM	BHP	RPM	BHP	RPM	BHP	RPM	BHP	RPM	BHP	RPM	BHP	RPM	BHP	RPM	BHP	RPM	BHP	RPM	BHP	RPM	BHP
<b>3 HP Standard Motor &amp; Drive</b>									<b>3 HP Standard Motor &amp; High Static Drive Accessory</b>												
4000	640	1.12	677	1.25	711	1.39	745	1.53	776	1.68	806	1.82	835	1.97	864	2.12	891	2.27	916	2.41	
4500	711	1.56	745	1.70	776	1.85	806	2.01	836	2.17	864	2.33	891	2.49	917	2.66	944	2.83	969	2.9	
5000	783	2.10	813	2.26	843	2.42	870	2.59	897	2.77	924	2.94	950	3.12	975	3.31	998	3.49	1022	3.68	
5500	855	2.76	883	2.93	910	3.11	936	3.29	961	3.49	986	3.67	1011	3.87	1035	4.07	1057	4.26	1079	4.46	
6000	928	3.54	954	3.74	979	3.93	1003	4.12	1027	4.33	1050	4.54	1072	4.74	1095	4.95	1117	5.16	1138	5.38	
<b>5 HP Oversized Motor &amp; Drive</b>																					

**Table PD-23 — Evaporator Fan Performance — 12½ Ton— Y\*D151C — Continued**

CFM	External Static Pressure (Inches of Water)																				
	1.10		1.20		1.30		1.40		1.50		1.60		1.70		1.80		1.90		2.00		
RPM	BHP	RPM	BHP	RPM	BHP	RPM	BHP	RPM	BHP	RPM	BHP	RPM	BHP	RPM	BHP	RPM	BHP	RPM	BHP	RPM	BHP
<b>3 HP Standard Motor Drive &amp; High Static Drive Accessory</b>									<b>5 HP Oversized Motor &amp; Drive</b>												
4000	940	2.56	964	2.71	987	2.86	1011	3.01	1034	3.16	1056	3.32	1077	3.47	1098	3.62	1120	3.79	1140	3.95	
4500	994	3.16	1016	3.32	1038	3.49	1059	3.66	1080	3.83	1102	4.00	1122	4.17	1143	4.34	1163	4.51	1183	4.68	
5000	1046	3.86	1069	4.05	1091	4.23	1112	4.41	1133	4.60	1152	4.78	1172	4.97	1190	5.15	1209	5.34	1228	5.53	
5500	1101	4.67	1122	4.87	1143	5.07	1165	5.27	1186	5.48	1206	5.69	—	—	—	—	—	—	—	—	
6000	1159	5.60	—	—	—	—	—	—	—	—	—	—	—	—	—	—	—	—	—	—	
<b>5 HP Oversized Motor &amp; Drive w/Field Supplied High Static Drive (1)</b>																					

For Standard Evaporator Fan Speed (RPM), reference Table PD-31.  
 For Standard Motor & High Static Drive Accessory/Fan Speed (RPM), reference Table PD-32.  
 For Oversize Evaporator Fan Speed (RPM), reference Table PD-33.  
 Data includes pressure drop due to filters and wet coils.  
 No accessories or options are included in pressure drop data.  
 Refer to Table PD-36 to determine add'l static pressure drop due to other options/accessories  
 Fan motor heat (MBH) = 3.15 x Fan Bhp.

Factory supplied motors, in commercial equipment, are definite purpose motors, specifically designed and tested to operate reliably and continuously at all cataloged conditions. Using the full horsepower range of our fan motors as shown in our tabular data will not result in nuisance tripping or premature motor failure. Our product's warranty will not be affected.

Notes:  
 1. Field Supplied Fan Sheave BK120. Field Supplied Belt may be necessary.



# Performance Data

# (12½ Ton) High Efficiency

**Table PD-24 – Evaporator Fan Performance – 12½ Ton – YCH151C – Standard Refrigeration System**

CFM	External Static Pressure (Inches of Water)																			
	.10		.20		.30		.40		.50		.60		.70		.80		.90		1.00	
	RPM	BHP	RPM	BHP	RPM	BHP	RPM	BHP	RPM	BHP	RPM	BHP	RPM	BHP	RPM	BHP	RPM	BHP	RPM	BHP
<b>3 HP Standard Motor &amp; Field Supplied Low Static Drive (1)</b>											<b>3 HP Standard Motor &amp; Drive</b>									
4000	—	—	—	—	520	1.01	550	1.13	580	1.25	610	1.38	638	1.51	666	1.65	693	1.80	720	1.95
4500	502	1.10	533	1.21	562	1.34	590	1.47	617	1.60	644	1.73	671	1.88	696	2.03	721	2.18	746	2.33
5000	551	1.47	579	1.61	606	1.74	632	1.87	657	2.02	682	2.17	706	2.31	730	2.46	754	2.63	777	2.80
5500	600	2.92	627	2.08	651	2.22	675	2.37	699	2.52	722	2.68	744	2.85	766	3.00	788	3.16	810	3.34
6000	649	2.46	675	2.64	698	2.79	720	2.94	742	3.11	764	3.28	785	3.46	805	3.64	825	3.81	845	3.98
<b>3 HP Standard Motor &amp; Drive</b>											<b>5 HP Oversized Motor &amp; Drive</b>									

**Table PD-24 – Evaporator Fan Performance – 12½ Ton – YCH151C – Continued**

CFM	External Static Pressure (Inches of Water)																			
	1.10		1.20		1.30		1.40		1.50		1.60		1.70		1.80		1.90		2.00	
	RPM	BHP	RPM	BHP	RPM	BHP	RPM	BHP	RPM	BHP	RPM	BHP	RPM	BHP	RPM	BHP	RPM	BHP	RPM	BHP
<b>3 HP Standard Motor &amp; Drive</b>											<b>3 HP Standard Motor &amp; High Static Drive</b>									
4000	746	2.10	771	2.26	795	2.41	819	2.57	842	2.72	864	2.89	886	3.05	908	3.22	929	3.40	951	3.58
4500	770	2.49	794	2.66	818	2.83	841	3.01	863	3.18	885	3.35	906	3.53	927	3.70	947	3.88	967	4.06
5000	799	2.96	821	3.13	843	3.31	865	3.49	887	3.68	908	3.87	929	4.07	949	4.26	969	4.45	988	4.64
5500	831	3.52	852	3.70	873	3.89	893	4.07	913	4.26	933	4.46	953	4.66	972	4.87	992	5.08	1011	5.29
6000	865	4.15	885	4.35	905	4.55	924	4.75	943	4.95	962	5.15	980	5.35	999	5.56	—	—	—	—
<b>5 HP Oversized Motor &amp; Drive</b>																				

For Standard Evaporator Fan Speed (RPM), reference Table PD-31.  
 For Standard Motor & High Static Drive Accessory/Fan Speed (RPM), reference Table PD-32.  
 For Oversize Evaporator Fan Speed (RPM), reference Table PD-33.  
 Data includes pressure drop due to filters and wet coils.  
 No accessories or options are included in pressure drop data.  
 Refer to Table PD-36 to determine add'l static pressure drop due to other options/accessories  
 Fan motor heat (MBH) = 3.15 x Fan Bhp.

Factory supplied motors, in commercial equipment, are definite purpose motors, specifically designed and tested to operate reliably and continuously at all cataloged conditions. Using the full horsepower range of our fan motors as shown in our tabular data will not result in nuisance tripping or premature motor failure. Our product's warranty will not be affected.

- Notes:  
 1. Field Supplied Fan Sheave BK115 required. Field Supplied Belt may be necessary.



# Performance Data

# (15 Ton) High Efficiency

**Table PD-25— Evaporator Fan Performance — 15 Ton — YC\*181C— Standard or TXV Refrigeration System**

CFM	External Static Pressure (Inches of Water)																			
	.10		.20		.30		.40		.50		.60		.70		.80		.90		1.00	
	RPM	BHP	RPM	BHP	RPM	BHP	RPM	BHP	RPM	BHP	RPM	BHP	RPM	BHP	RPM	BHP	RPM	BHP	RPM	BHP
<b>3 HP Standard Motor &amp; Field Supplied Low Static Drive (1)</b>										<b>3 HP Standard Motor &amp; Drive</b>										
4800	414	0.81	450	0.94	483	1.06	515	1.20	548	1.35	578	1.50	609	1.66	640	1.83	668	2.00	694	2.18
5400	456	1.11	490	1.26	520	1.39	549	1.54	578	1.70	607	1.87	635	2.03	662	2.21	689	2.39	716	2.58
6000	499	1.48	531	1.65	559	1.81	585	1.96	611	2.12	638	2.29	664	2.48	689	2.67	714	2.85	738	3.05
6600	542	1.92	572	2.12	599	2.3	624	2.46	648	2.63	671	2.81	695	3.00	719	3.20	743	3.41	765	3.62
7200	586	2.45	614	2.67	640	2.88	663	3.06	686	3.24	708	3.42	729	3.61	751	3.82	773	4.04	795	4.26
										<b>5 HP Oversized Motor &amp; Drive</b>										

**Table PD-25 — Evaporator Fan Performance — 15 Ton— YC\*181C — Continued**

CFM	External Static Pressure (Inches of Water)																				
	1.10		1.20		1.30		1.40		1.50		1.60		1.70		1.80		1.90		2.00		
	RPM	BHP	RPM	BHP	RPM	BHP	RPM	BHP	RPM	BHP	RPM	BHP	RPM	BHP	RPM	BHP	RPM	BHP	RPM	BHP	
<b>3 HP Standard Motor &amp; Drive</b>				<b>3 HP Standard Motor &amp; High Static Drive Accessory</b>																	
4800	719	2.36	744	2.55	769	2.75	792	2.95	815	3.14	838	3.34	859	3.54	880	3.73	901	3.93	921	4.13	
5400	742	2.77	766	2.97	789	3.17	811	3.38	833	3.59	855	3.81	876	4.03	897	4.26	917	4.48	937	4.70	
6000	763	3.25	788	3.46	811	3.68	833	3.89	855	4.11	875	4.33	896	4.56	916	4.80	935	5.04	955	5.28	
6600	788	3.82	810	4.03	832	4.26	855	4.49	877	4.72	898	4.96	918	5.20	937	5.43	956	5.67	—	—	
7200	816	4.49	837	4.71	857	4.94	889	5.17	898	5.41	919	5.66	—	—	—	—	—	—	—	—	
										<b>5 HP Oversized Motor &amp; Drive</b>											

For Standard Evaporator Fan Speed (RPM), reference Table PD-31.  
 For Standard Motor and High Static Drive (RPM), reference Table PD-32.  
 For Oversize Evaporator Fan Speed (RPM), reference Table PD-33.  
 Data includes pressure drop due to filters and wet coils.  
 No accessories or options are included in pressure drop data.  
 Refer to Table PD-36 to determine add'l static pressure drop due to other options/accessories  
 Fan motor heat (MBH) = 3.15 x Fan Bhp.  
 Notes:  
 1. Field Supplied Fan Sheave BK120 required. Field Supplied Belt May be necessary.

Factory supplied motors, in commercial equipment, are definite purpose motors, specifically designed and tested to operate reliably and continuously at all cataloged conditions. Using the full horsepower range of our fan motors as shown in our tabular data will not result in nuisance tripping or premature motor failure. Our product's warranty will not be affected.

**Table PD-26— Evaporator Fan Performance — 15 Ton — Y\*D181C — Dehumidification (Hot Gas Reheat) Option**

CFM	External Static Pressure (Inches of Water)																			
	.10		.20		.30		.40		.50		.60		.70		.80		.90		1.00	
	RPM	BHP	RPM	BHP	RPM	BHP	RPM	BHP	RPM	BHP	RPM	BHP	RPM	BHP	RPM	BHP	RPM	BHP	RPM	BHP
<b>3 HP Standard Motor &amp; Field Supplied Low Static Drive (1)</b>										<b>3 HP Standard Motor &amp; Drive</b>										
4800	427	0.88	463	1.03	496	1.16	527	1.31	557	1.46	586	1.61	614	1.77	641	1.93	667	2.10	693	2.29
5400	471	1.21	505	1.38	535	1.53	564	1.69	591	1.85	618	2.02	644	2.19	669	2.36	695	2.54	718	2.72
6000	516	1.61	547	1.81	576	1.98	603	2.15	628	2.33	653	2.51	677	2.70	700	2.88	724	3.07	747	3.26
6600	561	2.09	590	2.32	617	2.52	643	2.71	667	2.90	690	3.09	712	3.29	734	3.49	756	3.70	777	3.90
7200	607	2.67	634	2.92	659	3.16	683	3.36	707	3.56	728	3.77	749	3.98	770	4.20	791	4.42	811	4.64
										<b>5 HP Oversized Motor &amp; Drive</b>										

**Table PD-26 — Evaporator Fan Performance — 15 Ton— Y\*D181C — Continued**

CFM	External Static Pressure (Inches of Water)																			
	1.10		1.20		1.30		1.40		1.50		1.60		1.70		1.80		1.90		2.00	
	RPM	BHP	RPM	BHP	RPM	BHP	RPM	BHP	RPM	BHP	RPM	BHP	RPM	BHP	RPM	BHP	RPM	BHP	RPM	BHP
<b>3 HP Standard Motor &amp; Drive</b>				<b>3HP Motor and High Static Drive Accessory</b>										<b>5 HP Oversized Motor &amp; Drive</b>						
4800	719	2.49	742	2.69	765	2.89	787	3.09	808	3.28	829	3.48	849	3.68	869	3.89	887	4.09	906	4.29
5400	742	2.91	765	3.12	788	3.34	810	3.56	831	3.79	852	4.01	872	4.24	891	4.46	909	4.67	928	4.91
6000	769	3.46	791	3.66	812	3.87	833	4.09	855	4.33	874	4.57	894	4.81	913	5.06	932	5.31	950	5.56
6600	799	4.11	819	4.32	840	4.53	860	4.75	879	4.98	899	5.22	918	5.46	937	5.72	—	—	—	—
7200	830	4.86	850	5.09	870	5.31	888	5.54	—	—	—	—	—	—	—	—	—	—	—	—

For Standard Evaporator Fan Speed (RPM), reference Table PD-31.  
 For Standard Motor and High Static Drive (RPM), reference Table PD-32.  
 For Oversize Evaporator Fan Speed (RPM), reference Table PD-33.  
 Data includes pressure drop due to filters and wet coils.  
 No accessories or options are included in pressure drop data.  
 Refer to Table PD-36 to determine add'l static pressure drop due to other options/accessories  
 Fan motor heat (MBH) = 3.15 x Fan Bhp.  
 Notes:  
 1. Field Supplied Fan Sheave BK120 required. Field Supplied Belt may be necessary.

Factory supplied motors, in commercial equipment, are definite purpose motors, specifically designed and tested to operate reliably and continuously at all cataloged conditions. Using the full horsepower range of our fan motors as shown in our tabular data will not result in nuisance tripping or premature motor failure. Our product's warranty will not be affected.

\*Indicates both downflow and horizontal units.



# Performance Data

# (17½ Ton) High Efficiency

**Table PD-27— Evaporator Fan Performance — 17½ Ton — YC\*211C— Standard or TXV Refrigeration System**

CFM	External Static Pressure (Inches of Water)																			
	.10		.20		.30		.40		.50		.60		.70		.80		.90		1.00	
	RPM	BHP	RPM	BHP	RPM	BHP	RPM	BHP	RPM	BHP	RPM	BHP	RPM	BHP	RPM	BHP	RPM	BHP	RPM	BHP
	<b>5 HP Standard Motor &amp; Field Supplied Low Static Drive (1)</b>										<b>5 HP Standard Motor &amp; Drive</b>									
5600	—	—	—	—	533	1.52	561	1.67	589	1.83	617	2.00	644	2.18	670	2.35	697	2.53	723	2.73
6300	521	1.69	551	1.88	579	2.04	604	2.20	629	2.36	654	2.54	679	2.73	704	2.93	728	3.12	751	3.32
7000	571	2.27	600	2.48	626	2.68	650	2.85	673	3.03	695	3.20	718	3.40	740	3.60	763	3.82	785	4.04
7700	622	2.96	650	3.20	674	3.43	697	3.64	719	3.83	739	4.02	760	4.21	780	4.42	800	4.64	821	4.87
8400	674	3.80	700	4.05	723	4.31	745	4.55	765	4.77	785	4.98	804	5.18	823	5.39	841	5.62	860	5.85
											<b>5 HP Standard Motor &amp; High Static Drive Accessory</b>									
											<b>7.5 HP Oversized Motor &amp; Drive</b>									

**Table PD-27 — Evaporator Fan Performance — 17½ Ton— YC\*211C — Continued**

CFM	External Static Pressure (Inches of Water)																			
	1.10		1.20		1.30		1.40		1.50		1.60		1.70		1.80		1.90		2.00	
	RPM	BHP	RPM	BHP	RPM	BHP	RPM	BHP	RPM	BHP	RPM	BHP	RPM	BHP	RPM	BHP	RPM	BHP	RPM	BHP
	<b>5 HP Standard Motor &amp; Drive</b>										<b>5 HP Standard Motor &amp; High Static Drive Accessory</b>									
5600	749	2.93	773	3.13	796	3.33	818	3.54	840	3.75	861	3.98	882	4.20	903	4.43	923	4.66	943	4.89
6300	775	3.52	798	3.74	822	3.96	844	4.18	866	4.41	887	4.64	907	4.87	926	5.10	945	5.35	964	5.60
7000	806	4.26	828	4.48	849	4.70	870	4.93	891	5.17	912	5.41	932	5.66	952	5.92	971	6.17	990	6.42
7700	841	5.11	861	5.35	881	5.59	900	5.83	920	6.07	939	6.32	958	6.57	977	6.84	996	7.11	—	—
8400	878	6.09	897	6.34	916	6.61	934	6.87	953	7.14	971	7.40	988	7.66	—	—	—	—	—	—
	<b>7.5 HP Oversized Motor &amp; Drive</b>																			

For Standard Evaporator Fan Speed (RPM), reference Table PD-31.  
 For Standard Motor & High Static Drive Accessory/Fan Speed (RPM), reference Table PD-32.  
 For Oversize Evaporator Fan Speed (RPM), reference Table PD-33.  
 Data includes pressure drop due to filters and wet coils.  
 No accessories or options are included in pressure drop data.  
 Refer to Table PD-36 to determine add'l static pressure drop due to other options/accessories  
 Fan motor heat (MBH) = 3.15 x Fan Bhp.

Factory supplied motors, in commercial equipment, are definite purpose motors, specifically designed and tested to operate reliably and continuously at all cataloged conditions. Using the full horsepower range of our fan motors as shown in our tabular data will not result in nuisance tripping or premature motor failure. Our product's warranty will not be affected.

Notes:  
 1. Field Supplied Fan Sheave BK190 required. Field supplied belt may be necessary.

\*Indicates both downflow and horizontal units.



# Performance Data

# (20 Ton) High Efficiency

**Table PD-28— Evaporator Fan Performance — 20 Ton — YC\*241C— Standard or TXV Refrigeration System**

CFM	External Static Pressure (Inches of Water)																				
	.10		.20		.30		.40		.50		.60		.70		.80		.90		1.00		
RPM	BHP	RPM	BHP	RPM	BHP	RPM	BHP	RPM	BHP	RPM	BHP	RPM	BHP	RPM	BHP	RPM	BHP	RPM	BHP	RPM	BHP
<b>5 HP Standard Motor &amp; Field Supplied Low Static Drive (1)</b>						<b>5 HP Standard Motor &amp; Drive</b>															
6400	527	1.76	558	1.96	586	2.13	611	2.28	635	2.45	660	2.62	684	2.82	709	3.02	733	3.22	756	3.41	
7200	585	2.44	614	2.67	640	2.88	664	3.06	686	3.24	708	3.42	729	3.61	751	3.82	773	4.04	795	4.26	
8000	643	3.29	670	3.54	695	3.79	718	4.01	739	4.21	759	4.41	778	4.61	798	4.82	817	5.04	837	5.27	
8800	702	4.33	727	4.59	750	4.87	772	5.13	792	5.37	811	5.60	830	5.81	848	6.03	866	6.25	883	6.48	
9600	761	5.56	784	5.85	807	6.15	827	6.45	847	6.73	865	6.99	883	7.23	900	7.46	916	7.70	933	7.94	
						<b>7.5 HP Oversized Motor &amp; Drive</b>															

**Table PD-28— Evaporator Fan Performance — 20 Ton— YC\*241C — Continued**

CFM	External Static Pressure (Inches of Water)																				
	1.10		1.20		1.30		1.40		1.50		1.60		1.70		1.80		1.90		2.00		
RPM	BHP	RPM	BHP	RPM	BHP	RPM	BHP	RPM	BHP	RPM	BHP	RPM	BHP	RPM	BHP	RPM	BHP	RPM	BHP	RPM	BHP
<b>5 HP Standard Motor &amp; Drive</b>						<b>5 HP Standard Motor &amp; High Static Drive Accessory</b>															
6400	779	3.62	802	3.83	852	4.05	846	4.27	868	4.49	889	4.72	909	4.96	929	5.20	949	5.45	968	5.71	
7200	816	4.49	837	4.71	887	4.94	878	5.17	898	5.41	919	5.65	938	5.90	958	6.14	978	6.38	999	6.63	
8000	857	5.57	876	5.76	896	6.01	915	6.26	933	6.51	952	6.76	970	7.01	989	7.26	—	—	—	—	
8800	901	6.73	919	6.98	937	7.25	955	7.52	973	7.80	991	8.07	—	—	—	—	—	—	—	—	
9600	949	8.19	965	8.44	—	—	—	—	—	—	—	—	—	—	—	—	—	—	—	—	
						<b>7.5 HP Oversized Motor &amp; Drive</b>															

For Standard Evaporator Fan Speed (RPM), reference Table PD-31.  
 For Standard Motor & High Static Drive Accessory/Fan Speed (RPM), reference Table PD-32.  
 For Oversize Evaporator Fan Speed (RPM), reference Table PD-33.  
 Data includes pressure drop due to filters and wet coils.  
 No accessories or options are included in pressure drop data.  
 Refer to Table PD-36 to determine add'l static pressure drop due to other options/accessories  
 Fan motor heat (MBH) = 3.15 x Fan Bhp.  
 Notes:

Factory supplied motors, in commercial equipment, are definite purpose motors, specifically designed and tested to operate reliably and continuously at all cataloged conditions. Using the full horsepower range of our fan motors as shown in our tabular data will not result in nuisance tripping or premature motor failure. Our product's warranty will not be affected.

1. Field Supplied Fan Sheave BK190 required. Field supplied belt may be necessary.
2. 7.5 HP Oversize Motor with Field Supplied Motor Sheave 1VP50 required. Field Supplied Belt may be necessary.

**Table PD-29— Evaporator Fan Performance — 20 Ton — Y\*D241C — Dehumidification (Hot Gas Reheat) Option**

CFM	External Static Pressure (Inches of Water)																				
	.10		.20		.30		.40		.50		.60		.70		.80		.90		1.00		
RPM	BHP	RPM	BHP	RPM	BHP	RPM	BHP	RPM	BHP	RPM	BHP	RPM	BHP	RPM	BHP	RPM	BHP	RPM	BHP	RPM	BHP
<b>5 HP Standard Motor &amp; Field Supplied Low Static Drive (1)</b>						<b>5 HP Standard Motor &amp; Drive</b>															
6400	546	1.92	576	2.14	603	2.33	629	2.51	654	2.70	677	2.89	700	3.08	722	3.28	745	3.48	767	3.67	
7200	607	2.67	634	2.92	659	3.16	683	3.36	707	3.56	728	3.77	749	3.98	770	4.20	791	4.42	811	4.64	
8000	668	3.60	693	3.87	717	4.15	739	4.40	761	4.63	781	4.84	801	5.07	821	5.31	840	5.55	858	5.80	
8800	730	4.74	753	5.03	775	5.33	796	5.62	816	5.90	836	6.14	855	6.39	873	6.63	891	6.89	909	7.16	
9600	792	6.10	814	6.41	834	6.73	854	7.06	873	7.38	891	7.68	909	7.95	927	8.20	944	8.47	—	—	
						<b>7.5 HP Oversized Motor &amp; Drive</b>															

**7.5 HP Oversized Motor & Field Supplied Low Static Drive (2)**

**5 HP Standard Motor & High Static Drive Accessory**

**Table PD-29— Evaporator Fan Performance — 20 Ton— Y\*D241C — Continued**

CFM	External Static Pressure (Inches of Water)																				
	1.10		1.20		1.30		1.40		1.50		1.60		1.70		1.80		1.90		2.00		
RPM	BHP	RPM	BHP	RPM	BHP	RPM	BHP	RPM	BHP	RPM	BHP	RPM	BHP	RPM	BHP	RPM	BHP	RPM	BHP	RPM	BHP
<b>5 HP Standard Motor &amp; Drive</b>						<b>5 HP Standard Motor &amp; High Static Drive Accessory</b>															
6400	789	3.88	809	4.08	830	4.30	851	4.53	871	4.75	890	4.98	910	5.24	929	5.50	948	5.75	965	6.00	
7200	830	4.86	850	5.09	870	5.31	888	5.54	908	5.78	926	6.02	944	6.25	962	6.51	980	6.76	998	7.04	
8000	877	6.04	895	6.28	913	6.53	930	6.77	947	7.02	965	7.28	983	7.53	999	7.78	1016	8.05	1033	8.32	
8800	925	7.42	942	7.68	959	7.96	975	8.22	992	8.50	—	—	—	—	—	—	—	—	—	—	
9600	—	—	—	—	—	—	—	—	—	—	—	—	—	—	—	—	—	—	—	—	
						<b>7.5 HP Oversized Motor &amp; Drive</b>															

For Standard Evaporator Fan Speed (RPM), reference Table PD-31.  
 For Standard Motor & High Static Drive Accessory/Fan Speed (RPM), reference Table PD-32.  
 For Oversize Evaporator Fan Speed (RPM), reference Table PD-33.  
 Data includes pressure drop due to filters and wet coils.  
 No accessories or options are included in pressure drop data.  
 Refer to Table PD-36 to determine add'l static pressure drop due to other options/accessories  
 Fan motor heat (MBH) = 3.15 x Fan Bhp.  
 Notes:

Factory supplied motors, in commercial equipment, are definite purpose motors, specifically designed and tested to operate reliably and continuously at all cataloged conditions. Using the full horsepower range of our fan motors as shown in our tabular data will not result in nuisance tripping or premature motor failure. Our product's warranty will not be affected.

1. Field Supplied Fan Sheave BK190 required. Field supplied belt may be necessary.
2. 7.5 HP Oversize Motor with Field Supplied Motor Sheave 1VP50 required. Field Supplied Belt may be necessary.
3. Field Supplied Fan Sheave BK160 required. Field supplied belt may be necessary.

\*Indicates both downflow and horizontal units.





# Performance Data

# (25 Ton) High Efficiency

**Table PD-30 – Evaporator Fan Performance – 25 Ton – YC\*301C– Standard Refrigeration or TXV System**

CFM	External Static Pressure (Inches of Water)																			
	.10		.20		.30		.40		.50		.60		.70		.80		.90		1.00	
	RPM	BHP	RPM	BHP	RPM	BHP	RPM	BHP	RPM	BHP	RPM	BHP	RPM	BHP	RPM	BHP	RPM	BHP	RPM	BHP
<b>7.5 HP Standard Motor &amp; Drive</b>																				
8000	643	3.29	670	3.54	695	3.79	718	4.01	739	4.21	759	4.41	778	4.61	798	4.82	817	5.04	837	5.27
8500	680	3.92	705	4.18	729	4.44	752	4.69	772	4.92	792	5.13	810	5.33	829	5.55	847	5.77	865	6.00
9000	717	4.61	741	4.89	764	5.17	786	5.44	806	5.69	825	5.92	843	6.14	861	6.36	878	6.59	895	6.83
9500	754	5.39	777	5.68	799	5.98	820	6.27	840	6.55	859	6.80	876	7.04	893	7.27	910	7.50	926	7.74
10000	791	6.26	813	6.56	835	6.87	855	7.18	874	7.48	893	7.76	910	8.02	926	8.27	942	8.51	—	—
10500	828	7.21	850	7.52	870	7.85	890	8.18	909	8.50	—	—	—	—	—	—	—	—	—	—
11000	866	8.26	886	8.59	—	—	—	—	—	—	—	—	—	—	—	—	—	—	—	—

**7.5 HP Standard Motor & Low Static Drive Accessory**

**7.5 HP Standard Motor & High Static Drive Accessory**

**Table PD-30– Evaporator Fan Performance – 25 Ton – YC\*301C– Continued**

CFM	External Static Pressure (Inches of Water)									
	1.10		1.20		1.30		1.40		1.50	
	RPM	BHP	RPM	BHP	RPM	BHP	RPM	BHP	RPM	BHP
<b>7.5 HP Standard Motor &amp; Drive</b>										
8000	857	5.51	876	5.76	896	6.01	915	6.26	933	6.51
8500	884	6.24	903	6.50	921	6.76	940	7.03	958	7.30
9000	913	7.07	930	7.32	948	7.59	965	7.86	983	8.15
9500	943	7.99	959	8.25	976	8.51	—	—	—	—
10000	—	—	—	—	—	—	—	—	—	—
10500	—	—	—	—	—	—	—	—	—	—
11000	—	—	—	—	—	—	—	—	—	—

**7.5 HP Standard Motor & High Static Drive Accessory**

For Standard Evaporator Fan Speed (RPM), reference Table PD-31.  
 For Standard Motor & High Static Drive, reference Table PD-32.  
 For Standard Motor & Low Static Drive, reference Table PD-34.

Notes:

Data includes pressure drop due to filters and wet coils.

No accessories or options are included in pressure drop data.

Refer to Table PD-36 to determine add'l static pressure drop due to other options/accessories

Fan motor heat (MBH) = 3.15 x Fan Bhp.

Factory supplied motors, in commercial equipment, are definite purpose motors, specifically designed and tested to operate reliably and continuously at all cataloged conditions. Using the full horsepower range of our fan motors as shown in our tabular data will not result in nuisance tripping or premature motor failure. Our product's warranty will not be affected.

\*Indicates both downflow and horizontal units.



# Performance Data

(12½ - 25 Tons)

**Table PD-31— Standard Motor & Drive/Fan Speed (Rpm)**

Tons	Unit Model No.	6Turns Open	5Turns Open	4Turns Open	3Turns Open	2Turns Open	1Turn Open	Closed
12½	YC*150D3,4,W, YC*151C3,4,W	640	680	720	760	800	840	N/A
	YC*150DK	705	756	806	857	907	957	N/A
15	YC*180B3,4,W	679	721	764	806	849	891	N/A
	YC*180BK	N/A	680	733	785	837	889	941
	YC*181C3,4,W	560	600	640	680	720	760	N/A
17½	YC*210C3,4,W	869	923	978	1032	1087	1141	N/A
	YC*210CK	869	324	978	1032	1087	1141	N/A
	YC*211C3,4,W	615	659	703	747	791	835	N/A
20	YC*240B3,4,W, YC*241C3,4,W	615	659	703	747	791	835	N/A
	YC*240BK	590	627	664	701	738	775	N/A
25	YC*300B3,4,W, YC*301C3,4,W	705	742	779	817	854	891	N/A
	YC*300BK	701	738	775	812	849	886	N/A

Factory set at 3 turns open.

**Table PD-32— Standard Motor & High Static Drive Accessory/Fan Speed (Rpm)**

Tons	Unit Model No.	6Turns Open	5Turns Open	4Turns Open	3Turns Open	2Turns Open	1Turn Open	Closed
12½	YC*151C3,4,W	807	857	908	958	1009	1059	N/A
15	YC*180B3,4,W	806	849	891	934	976	1019	N/A
	YC*181B3,4,W	640	680	720	760	800	840	N/A
17½	YC*211C3,4,W	835	879	923	967	1011	1055	N/A
20	YC*240B/241C3,4,W	835	879	923	967	1011	1055	N/A
25	YC*300B/301C3,4,W	816	853	890	928	965	1002	N/A

**Table PD-33— Oversized Motor & Drive/Fan Speed (Rpm)**

Tons	Unit Model No.	6Turns Open	5Turns Open	4Turns Open	3Turns Open	2Turns Open	1Turn Open	Closed
12½	YC*150D,151C3,4,W	869	923	978	1032	1087	1141	N/A
15	YC*180B3,4,W	806	856	907	957	1008	1058	N/A
	YC*181C3,4,W	705	755	806	856	907	957	N/A
17½	YC*210C3,4,W	949	1008	1068	1127	1187	1246	N/A
	YC*211C3,4,W	816	853	890	928	965	1002	N/A
20	YC*240B3,4,W, YC*241C3,4,W	816	853	890	928	965	1002	N/A

**Table PD-34 — Low Static Fan Drive**

Tons	Unit Model No.	6Turns Open	5Turns Open	4Turns Open	3Turns Open	2Turns Open	1Turn Open	Closed
17½	YC*210C3,4,W	705	755	806	856	907	957	N/A
25	YC*300B3,4,W,301C3,4,W	594	631	668	705	742	779	N/A

\*Indicates both downflow and horizontal units.



# Performance Data

(12½ - 25 Tons)

**Table PD-35 — Gas-Fired Heating Capacities**

Tons	Unit Model No.	Heating Input MBH	Heating Output MBH	Air Temp. Rise, F
12½	YC*150D-L1 ,YC*151C-L1	150/100	122/81	10-40
	YC*150D-H1,YC*151C-H1	250/175	203/142	25-55
15	YC*180B-L1	250/175	203/142	25-55
	YC*180B-H1,YC*181C-H1	350/250	284/203	35-65
	YC*181C-L1	250/175	203/142	15-45
17½	YC*210C-L1 ,YC*211C-L1	250/175	203/142	15-45
	YC*210C-H1,YC*211C-H1	350/250	284/203	35-65
20	YC*240B-L1 ,YC*241C-L1	250/175	203/142	15-45
	YC*240B-H1,YC*241C-H1	400/300	324/243	25-55
25	YC*300B-L1,YC*301C-L1	250/175	203/142	15-45
	YC*300B-H1,YC*301C-H1	400/300	324/243	25-55

Note:

1. Second stage is total heating capacity. Second Stage / First Stage.

\*Indicates both downflow and horizontal units.



# Performance Data

(12½ - 25 Tons)

**Table PD-36 — Static Pressure Drops Through Accessories (Inches Water Column)**

Tons	Unit Model No.	CFM	Standard Filters <sup>1</sup>	Through Reheat Coil	2 Inch Pleated Filters <sup>3</sup>	Economizer with OA/RA Dampers <sup>2</sup>	
						100% OA	100% RA
12½	YC*150D, YCH151C	4000	0.05	—	0.08	0.19	0.02
		5000	0.07	—	0.11	0.26	0.03
		6000	0.10	—	0.15	0.33	0.04
	YCD151C	2500	0.02	0.01	0.03	0.07	0.01
		4000	0.05	0.03	0.08	0.19	0.02
		5000	0.07	0.05	0.11	0.26	0.03
15	YC*180B	4800	0.07	—	0.10	0.25	0.03
		6000	0.10	—	0.15	0.33	0.04
		7200	0.15	—	0.19	0.40	0.05
	YCD181C	3000	0.02/0.01	0.01	0.03/0.02	0.07	0.03
		4800	0.04/0.03	0.02	0.07/0.06	0.14	0.03
		6000	0.06/0.05	0.03	0.10/0.09	0.20	0.04
YCH181C	7200	0.09/0.07	0.04	0.13/0.11	0.27	0.05	
	4800	0.04/0.03	—	0.07/0.06	0.14	0.03	
	6000	0.06/0.05	—	0.10/0.09	0.20	0.04	
17½	YC*210C	7200	0.09/0.07	—	0.13/0.11	0.27	0.05
		5600	0.09	—	0.13	0.30	0.04
		7000	0.14	—	0.18	0.39	0.05
	YCD211C	8400	0.20	—	0.24	0.47	0.06
		3500	0.02/0.02	—	0.03/0.03	0.09	0.03
		5600	0.06/0.05	—	0.09/0.08	0.18	0.04
YCH211C	7000	0.09/0.07	—	0.13/0.11	0.26	0.04	
	8400	0.12/0.10	—	0.17/0.14	0.35	0.06	
	5600	0.06/0.05	—	0.09/0.08	0.18	0.04	
20	YCD240	7000	0.09/0.07	—	0.13/0.11	0.26	0.04
		8400	0.12/0.10	—	0.17/0.14	0.35	0.06
		5600	0.06/0.05	—	0.09/0.08	0.18	0.04
	YCD241C	7000	0.09/0.07	—	0.13/0.11	0.26	0.04
		8400	0.12/0.10	—	0.17/0.14	0.35	0.06
		5600	0.06/0.05	—	0.09/0.08	0.18	0.04
YCH240, 241C	7000	0.09/0.07	—	0.13/0.11	0.26	0.04	
	8400	0.12/0.10	—	0.17/0.14	0.35	0.06	
	5600	0.06/0.05	—	0.09/0.08	0.18	0.04	
25	YCD300B	6400	0.07	—	0.11	0.22	0.04
		8000	0.11	—	0.15	0.32	0.05
		9600	0.16	—	0.20	0.44	0.07
	YCD301C	4000	0.03	0.02	0.04	0.11	0.03
		6400	0.07	0.04	0.11	0.22	0.04
		8000	0.11	0.05	0.15	0.32	0.05
YCH300B, 301C	9600	0.16	0.07	0.20	0.44	0.07	
	7000	0.09	—	0.13	0.26	0.04	
	9000	0.14	—	0.18	0.40	0.07	
25	YCD300B	11000	0.21	—	0.25	0.57	0.10
		7000	0.09	—	0.13	0.26	0.04
		9000	0.14	—	0.18	0.40	0.07
	YCD301C	11000	0.21	—	0.25	0.57	0.10
		7000	0.09	—	0.13	0.26	0.04
		9000	0.14	—	0.18	0.40	0.07
YCH300B, 301C	11000	0.21	—	0.25	0.57	0.10	
	7000	0.07	—	0.11	0.26	0.04	
	9000	0.11	—	0.15	0.40	0.07	
		11000	0.17	—	0.22	0.57	0.10

Notes:

1. 2" filters standard on the 12½-25 tons.
2. OA = Outside Air and RA = Return Air.
3. Difference in pressure drop should be considered when utilizing optional 2" pleated filters.

# Performance Data

**Table PD-37— Hot Gas Reheat Temperature Rise<sup>2,3</sup>**

		Leaving Evaporator Dry Bulb [F] <sup>1</sup>						
Tons	SCFM	35	40	45	50	55	60	65
12½	2500	23.4	23.8	25.0	26.9	29.5	32.9	37.0
	3000	21.4	21.6	22.5	24.0	26.0	28.7	31.9
	3500	19.5	19.7	20.4	21.5	23.1	25.2	27.7
	4000	17.8	18.1	18.6	19.6	20.9	22.5	24.5
	4500	16.3	16.7	17.3	18.1	19.2	20.5	22.1
	5000	14.9	15.5	16.2	17.1	18.0	19.2	20.4
	5500	13.5	14.4	15.3	16.2	17.2	18.1	19.1
6000	12.1	13.4	14.6	15.7	16.7	17.6	18.3	
Tons	SCFM	35	40	45	50	55	60	65
15	3000	34.4	36.7	38.9	41.2	43.5	45.8	48.1
	3600	29.3	31.2	33.1	35.0	36.9	38.8	40.8
	4200	25.4	27.0	28.6	30.2	31.9	33.5	35.1
	4800	22.3	23.7	25.1	26.5	27.9	29.3	30.7
	5400	19.9	21.2	22.4	23.7	24.9	26.2	27.4
	6000	18.0	19.1	20.3	21.4	22.5	23.7	24.8
	6600	16.4	17.5	18.6	19.6	20.7	21.7	22.8
7200	15.1	16.1	17.1	18.1	19.1	20.1	21.1	
Tons	SCFM	35	40	45	50	55	60	65
20	4000	22.0	22.5	23.6	25.4	27.7	30.6	34.0
	4800	19.1	19.8	20.9	22.3	24.0	26.1	28.5
	5600	16.6	17.4	18.4	19.5	20.9	22.4	24.0
	6400	14.7	15.5	16.3	17.2	18.2	19.3	20.6
	7200	13.5	14.1	14.7	15.4	16.2	17.0	17.9
	8000	12.9	13.2	13.7	14.2	14.8	15.5	16.2
	8800	12.5	12.9	13.3	13.7	14.2	14.8	15.4
9600	12.4	12.8	13.1	13.5	13.9	14.5	15.0	

**Notes:**

1. Temperature rise does not account for indoor fan heat.
2. 70 deg OD Ambient Temperature.
3. For units with the Dehumidification (Hot Gas Reheat) option.

# Controls

## Field Installed Control Options

### Zone Sensors

Zone sensors are the building occupant's comfort control devices. They replace the conventional electro-mechanical thermostats. The following zone sensor options are available for Voyager units with the ReliaTel™ control:

#### Manual Changeover

Heat, Cool or Off System Switch. Fan Auto or Off Switch. One temperature setpoint lever.

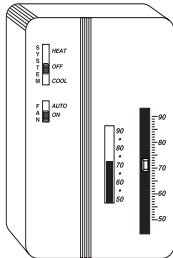

#### Manual/Automatic Changeover

Auto, Heat, Cool or Off System Switch. Fan Auto or Off Switch. Two temperature setpoint levers. Optional Status Indication LED lights, System On, Heat, Cool, or Service.

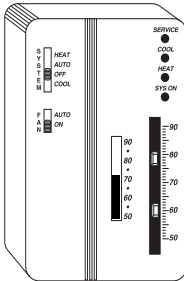

#### Remote Sensor

Sensor(s) available for all zone sensors to provide remote sensing capabilities.

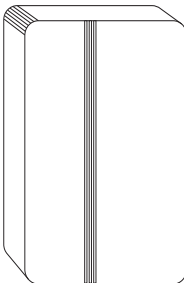

#### Dual Thermistor Remote Zone Sensor

This sensor will allow the customer to reduce the total number of remote sensors to obtain space temperature averaging. This sensor should be utilized with ReliaTel controls.

### Digital Display Zone Sensor

The Digital LCD (Liquid Crystal Display) zone sensor has the look and functionality of standard zone sensors. This sensor includes a digital display of set point adjustment and space temperature in F (Fahrenheit) or C (Celsius). Includes FAN and SYSTEM buttons (supports the service functions of the standard sensor). E-squared memory stores last programmed set points. Requires 24 VAC (Volts AC). This sensor should be utilized with ReliaTel™ controls.

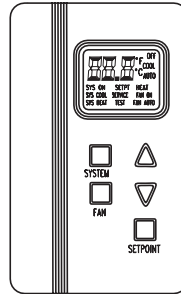

### Programmable Night Setback

Auto or manual changeover with seven-day programming. Keyboard selection

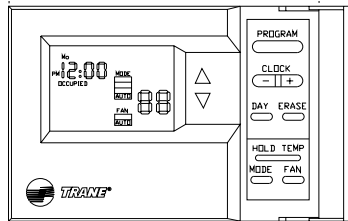

of Heat, Cool, Fan, Auto, or On. All programmable sensors have System On, Heat, Cool, Service LED/indicators as standard. Night Setback Sensors have one (1) Occupied, one (1) Un-occupied, and two (2) Override programs per day.

### Integrated Comfort™ System

Sensor(s) available with optional temperature adjustment and override buttons to provide central control through a Trane Integrated Comfort™ system.

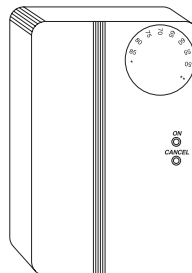

**CO<sub>2</sub> Sensing** The CO<sub>2</sub> sensor has the ability to monitor space occupancy levels within the building by measuring the parts per million of CO<sub>2</sub> (Carbon Dioxide) in the air. As the CO<sub>2</sub> levels increase, the outside air damper modulates to meet the CO<sub>2</sub> space ventilation requirements. The CO<sub>2</sub> sensor kit is available as a field installed accessory.

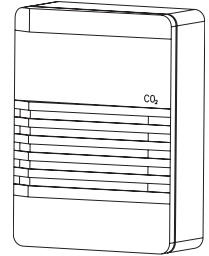

### Economizer Controls

The standard equipment offering is a fixed dry bulb changeover control. In addition, there are two optional controls, Enthalpy and Differential Enthalpy Control.

### Enthalpy Control

Replaces the dry bulb control with a wet bulb changeover controller which has a fully adjustable set point. Enthalpy control offers a higher level of comfort control, along with energy savings potential, than the standard dry bulb control. This is due to the additional wet bulb sensing capability.

### Differential Enthalpy

Replaces the standard dry bulb control with two enthalpy sensors that compare total heat content of the indoor air and outdoor air to determine the most efficient air source. This control option offers the highest level of comfort control, plus energy efficiency, available.

### Remote Potentiometer

Minimum position setting of economizer can be remotely adjusted with this accessory.

### Differential Pressure Switches

This factory or field-installed option allows individual fan failure and dirty filter indication. The fan failure switch will disable all unit functions and "flash" the Service LED on the zone sensor. The dirty filter switch will light the Service LED on the zone sensor and will allow continued unit operation.

### Trane Communication Interface (TCI)

This factory or field-installed micro-processor interface allows the unit to communicate to Trane's Integrated Comfort™ system.



# Electrical Data

**Table ED-1 – Electrical Characteristics – Evaporator Fan Motors – 60 Cycle**

Tons	Unit Model No.	Standard Evaporator Fan Motor						Oversized Evaporator Fan Motor					
		No.	Volts	Phase	HP	Amps		No.	Volts	Phase	HP	Amps	
						FLA	LRA					FLA	LRA
12½	YC*150D3, YC*151C3	1	208-230	3	3.00	10.6	81.0	1	208-230	3	5.00	16.7	109.8
	YC*150D4, YC*151C4	1	460	3	3.00	4.8	40.5	1	460	3	5.00	7.6	54.9
	YC*150DW, YC*151CW	1	575	3	3.00	3.9	31.0	1	575	3	5.00	6.1	41.6
	YC*150DK	1	380	3	5.0	9.2	66.5	–	–	–	–	–	–
15	YC*180B3, YC*181C3	1	208-230	3	3.00	10.6	81.0	1	208-230	3	5.00	16.7	109.8
	YC*180B4, YC*181C4	1	460	3	3.00	4.8	40.5	1	460	3	5.00	7.6	54.9
	YC*180BW, YC*181CW	1	575	3	3.00	3.9	31.0	1	575	3	5.00	6.1	41.6
	YC*180BK	1	380	3	5.0	9.2	66.5	–	–	–	–	–	–
17½	YC*210C3, YC*211C3	1	208-230	3	5.00	16.7	109.8	1	208-230	3	7.50	24.2	120.4
	YC*210C4, YC*211C4	1	460	3	5.00	7.6	54.9	1	460	3	7.50	11.0	74.0
	YC*210CW, YC*211CW	1	575	3	5.00	6.1	41.6	1	575	3	7.50	9.0	60.0
	YC*210CK	1	380	3	7.5	13.3	83.5	–	–	–	–	–	–
20	YC*240B3, YC*241C3	1	208-230	3	5.00	16.7	109.8	1	208-230	3	7.50	24.2	120.4
	YC*240B4, YC*241C4	1	460	3	5.00	7.6	54.9	1	460	3	7.50	11.0	74.0
	YC*240BW, YC*241CW	1	575	3	5.00	6.1	41.6	1	575	3	7.50	9.0	60.0
	YC*240BK	1	380	3	7.5	13.3	83.5	–	–	–	–	–	–
25	YC*300B3, YC*301C3	1	208-230	3	7.50	24.2	120.4	–	–	–	–	–	–
	YC*300B4, YC*301C4	1	460	3	7.50	11.0	74.0	–	–	–	–	–	–
	YC*300BW, YC*301CW	1	575	3	7.50	9.0	60.0	–	–	–	–	–	–
	YC*300BK	1	380	3	7.5	13.3	83.5	–	–	–	–	–	–

**Table ED-2 – Electrical Characteristics – Compressor Motor And Condenser Motor – 60 Cycle – Standard Efficiency**

Tons	Unit Model No.	Compressor Motor						Condenser Fan Motors					
		No.	Volts	Phase	HP <sup>B</sup>	RPM	Amps <sup>1</sup>		No.	Phase	HP	Amps <sup>1</sup>	
							RLA	LRA				FLA	LRA
12½	YC*150D3	2	208-230	3	6.0	3450	20.4	156	2	1	.50	3.2	8.8
	YC*150D4	2	460	3	6.0	3450	10.8	75	2	1	.50	1.6	3.8
	YC*150DW	2	575	3	6.0	3450	8.3	54	2	1	.50	1.3	3.2
	YC*150DK	2	380	3	6.0	3450	13.1	70	2	1	.50	1.9	5.2
15	YC*180B3	2	208-230	3	9.3/5.1	3450	31.9/20.7	253/128	2	1	.50	3.2	8.8
	YC*180B4	2	460	3	9.3/5.1	3450	16.3/10.0	113/63	2	1	.50	1.6	3.8
	YC*180BW	2	575	3	9.3/5.1	3450	13.1/7.4	85/49	2	1	.50	1.3	3.2
	YC*180BK	2	380	3	9.3/5.1	3450	19.7/12.1	125/64	2	1	.50	1.9	5.2
17½	YC*210C3	2	208-230	3	9.3/6.0	3450	31.5/20.8	253/156	2	1	1.00	5.5	18.3
	YC*210C4	2	460	3	9.3/6.0	3450	15.9/10.0	113/75	2	1	1.00	2.9	9.3
	YC*210CW	2	575	3	9.3/6.0	3450	12.8/8.2	85/54	2	1	1.00	2.0	5.7
	YC*210CK	2	380	3	9.3/6.0	3450	19.2/12.1	125/70	2	1	1.00	3.5	8.5
20	YC*240B3	2	208-230	3	9.3	3450	31.7	253	2	1	1.00	5.5	18.3
	YC*240B4	2	460	3	9.3	3450	16.2	113	2	1	1.00	2.9	9.3
	YC*240BW	2	575	3	9.3	3450	13.0	85	2	1	1.00	2.0	5.7
	YC*240BK	2	380	3	9.3	3450	19.6	125	2	1	1.00	3.5	8.5
25	YC*300B3	2	208-230	3	10.0	3450	36.6	278	2	1	1.00	5.5	18.3
	YC*300B4	2	460	3	10.0	3450	17.9	124	2	1	1.00	2.9	9.3
	YC*300BW	2	575	3	10.0	3450	14.9	92	2	1	1.00	2.0	5.7
	YC*300BK	2	380	3	10.0	3450	21.7	137	2	1	1.00	3.5	8.5

Notes:

1. Amp draw for each motor; multiply value by number of motors to determine total amps.
2. HP for each compressor.

\*Indicates both downflow and horizontal units.



# Electrical Data

(High Efficiency)

**Table ED-3 – Electrical Characteristics – Compressor Motor And Condenser Motor – 60 Cycle – High Efficiency  
Standard Refrigeration System**

Tons	Unit Model No.	Compressor Motor							Condenser Fan Motors				
		No.	Volts	Phase	HP <sup>2</sup>	RPM	Amps <sup>1</sup>		No.	Phase	HP	Amps <sup>1</sup>	
							FLA	LRA				FLA	LRA
12½	YC*151C3	2	208-230	3	5.7	3450	20.7	156	2	1	.50	3.2	8.8
	YC*151C4	2	460	3	5.7	3450	10.0	75	2	1	.50	1.6	3.8
	YC*151CW	2	575	3	5.7	3450	8.2	54	2	1	.50	1.3	3.2
15	YC*181C3	2	208-230	3	9.3/4.5	3450	31.5/16.9	253/124	2	1	.50	3.2	8.8
	YC*181C4	2	460	3	9.3/4.5	3450	15.1/8.2	113/59.6	2	1	.50	1.6	3.8
	YC*181CW	2	575	3	9.3/4.5	3450	12.1/6.6	85/49.4	2	1	.50	1.3	3.2
17½	YC*211C3	2	208-230	3	10.0/5.7	3450	33.3/20.7	278/156	2	1	1.00	5.5	18.3
	YC*211C4	2	460	3	10.0/5.7	3450	16.3/10.0	124/75	2	1	1.00	2.9	9.3
	YC*211CW	2	575	3	10.0/5.7	3450	13.2/8.2	92/54	2	1	1.00	2.0	5.7
20	YC*241C3	2	208-230	3	9.30	3450	31.6	253	2	1	1.00	5.5	18.3
	YC*241C4	2	460	3	9.30	3450	16.1	113	2	1	1.00	2.9	9.3
	YC*241CW	2	575	3	9.30	3450	12.9	85	2	1	1.00	2.0	5.7
25	YC*301C3	2	208-230	3	10.00	3450	37.6	278	2	1	1.00	5.5	18.3
	YC*301C4	2	460	3	10.00	3450	18.3	124	2	1	1.00	2.9	9.3
	YC*301CW	2	575	3	10.00	3450	14.9	92	2	1	1.00	2.0	5.7

Notes:  
1. Amp draw for each motor; multiply value by number of motors to determine total amps.  
2. HP for each compressor.

**Table ED-4 – Electrical Characteristics – Compressor Motor And Condenser Motor – 60 Cycle – High Efficiency, TXV/Face-Split  
Evaporator Coil Option (Downflow Only)**

Tons	Unit Model No.	Compressor Motor							Condenser Fan Motors				
		No.	Volts	Phase	HP <sup>2</sup>	RPM	Amps <sup>1</sup>		No.	Phase	HP	Amps <sup>1</sup>	
							FLA	LRA				FLA	LRA
12½	YCD151C3	2	208-230	3	5.7/5.7	3450	18.6/18.6	156/156	2	1	.50	3.2	8.8
	YCD151C4	2	460	3	5.7/5.7	3450	9.4/9.4	75/75	2	1	.50	1.6	3.8
	YCD151CW	2	575	3	5.7/5.7	3450	7.4/7.4	54/54	2	1	.50	1.3	3.2
15	YCD181C3	2	208-230	3	9.3/4.5	3450	32.1/16.4	253/124	2	1	.50	3.2	8.8
	YCD181C4	2	460	3	9.3/4.5	3450	15.6/8.7	113/59.6	2	1	.50	1.6	3.8
	YCD181CW	2	575	3	9.3/4.5	3450	12.3/7.4	85/49.4	2	1	.50	1.3	3.2
17½	YCD211C3	2	208-230	3	10.00/5.7	3450	34.8/19.5	278/156	2	1	1.00	5.5	18.3
	YCD211C4	2	460	3	10.00/5.7	3450	17.0/10.3	124/75	2	1	1.00	2.9	9.3
	YCD211CW	2	575	3	10.00/5.7	3450	13.8/8.1	92/54	2	1	1.00	2.0	5.7
20	YCD241C3	2	208-230	3	9.0/9.3	3500/3450	30.4/32.6	225/253	2	1	1.00	5.5	18.3
	YCD241C4	2	460	3	9.0/9.3	3500/3450	16.1/16.8	114/113	2	1	1.00	2.9	9.3
	YCD241CW	2	575	3	9.0/9.3	3500/3450	12.5/13.4	80/85	2	1	1.00	2.0	5.7
25	YCD301C3	2	208-230	3	10.00	3450	36.2	278	2	1	1.00	5.5	18.3
	YCD301C4	2	460	3	10.00	3450	17.7	124	2	1	1.00	2.9	9.3
	YCD301CW	2	575	3	10.00	3450	14.3	92	2	1	1.00	2.0	5.7

Notes:  
1. Amp draw for each motor; multiply value by number of motors to determine total amps.  
2. HP for each compressor.

**Table ED-5 – Electrical Characteristics – Compressor Motor And Condenser Motor – 60 Cycle – Dehumidification (Hot Gas Reheat) Option  
(Downflow Only)**

Tons	Unit Model No.	Compressor Motor							Condenser Fan Motors				
		No.	Volts	Phase	HP <sup>2</sup>	RPM	Amps <sup>1</sup>		No.	Phase	HP	Amps <sup>1</sup>	
							FLA	LRA				FLA	LRA
12½	YCD151C3	2	208-230	3	5.7/5.7	3450	18.6/18.6	156/156	2	1	.50	3.2	8.8
	YCD151C4	2	460	3	5.7/5.7	3450	9.7/9.7	75/75	2	1	.50	1.6	3.8
	YCD151CW	2	575	3	5.7/5.7	3450	7.6/7.6	54/54	2	1	.50	1.3	3.2
15	YCD181C3	2	208-230	3	8.3/5.7	3450	27.4/19.0	208/156	2	1	.50	3.2	8.8
	YCD181C4	2	460	3	8.3/5.7	3450	13.8/10.1	100/75	2	1	.50	1.6	3.8
	YCD181CW	2	575	3	8.3/5.7	3450	10.7/7.9	68/54	2	1	.50	1.3	3.2
20	YCD241C3	2	208-230	3	9.0/9.3	3500/3450	30.1/13.7	225/253	2	1	1.00	5.5	18.3
	YCD241C4	2	460	3	9.0/9.3	3500/3450	15.6/16.2	114/113	2	1	1.00	2.9	9.3
	YCD241CW	2	575	3	9.0/9.3	3500/3450	12.1/13.0	80/85	2	1	1.00	2.0	5.7

Notes:  
1. Amp draw for each motor; multiply value by number of motors to determine total amps.  
2. HP for each compressor.

\*Indicates both downflow and horizontal units.





# Electrical Data

## (Standard Efficiency)

**Table ED-6 — Unit Wiring - Standard Efficiency**

Tons	Unit Model No.	Unit Operating Voltage Range	Standard Indoor Fan Motor		Oversize Indoor Fan Motor	
			Minimum Circuit Ampacity <sup>2</sup>	Maximum Fuse Size or Maximum Circuit Breaker <sup>1</sup>	Minimum Circuit Ampacity <sup>2</sup>	Maximum Fuse Size or Maximum Circuit Breaker <sup>1</sup>
12½	YC*150D3	187-253	63	80	69	80
	YC*150D4	414-506	33	40	36	40
	YC*150DW	517-633	26	30	28	35
	YC*150DK	342-418	43	50	—	—
15	YC*180B3	187-253	78	90	84	100
	YC*180B4	414-506	39	50	42	50
	YC*180BW	517-633	31	40	30	40
	YC*180BK	342-418	50	60	—	—
17½	YC*210C3	187-253	88	100	96	125
	YC*210C4	414-506	44	50	47	60
	YC*210CW	517-633	35	45	38	45
	YC*210CK	342-418	57	70	—	—
20	YC*240B3	187-253	100	125	107	125
	YC*240B4	414-506	50	60	54	60
	YC*240BW	517-633	40	45	43	50
	YC*240BK	342-518	65	80	—	—
25	YC*300B3	187-253	118	150	—	—
	YC*300B4	414-506	58	70	—	—
	YC*300BW	517-633	46	50	—	—
	YC*300BK	342-418	70	80	—	—

Notes:

1. HACR breaker per NEC.
2. MCA values do not include Power Exhaust accessory. See Table ED-7 for this information.

\*Indicates both downflow and horizontal units.



# Electrical Data

## (High Efficiency)

**Table ED-7— Unit Wiring - High Efficiency— Standard Refrigeration System**

Tons	Unit Model No.	Unit Operating Voltage Range	Standard Indoor Fan Motor		Oversize Indoor Fan Motor	
			Minimum Circuit Ampacity <sup>2</sup>	Maximum Fuse Size or Maximum Circuit Breaker <sup>1</sup>	Minimum Circuit Ampacity <sup>2</sup>	Maximum Fuse Size or Maximum Circuit Breaker <sup>1</sup>
12½	YC*151C3	187-253	64	80	70	90
	YC*151C4	414-506	31	40	34	40
	YC*151CW	517-633	25	30	28	35
15	YC*181C3	187-253	74	90	80	100
	YC*181C4	414-506	36	50	38	50
	YC*181CW	517-633	29	40	31	40
17½	YC*211C3	187-253	91	110	98	125
	YC*211C4	414-506	44	60	48	60
	YC*211CW	517-633	35	45	38	50
20	YC*241C3	187-253	99	125	107	125
	YC*241C4	414-506	50	60	54	60
	YC*241CW	517-633	40	50	43	50
25	YC*301C3	187-253	120	150	N/A	N/A
	YC*301C4	414-506	58	70	N/A	N/A
	YC*301CW	517-633	47	60	N/A	N/A

Notes:

1. HACR breaker per NEC.
2. MCA values do not include Power Exhaust accessory. See Table ED-7 for this information.

**Table ED-8 — Unit Wiring - High Efficiency, TXV/Face-Split Evaporator Coil Option (Downflow Only)**

Tons	Unit Model No.	Unit Operating Voltage Range	Standard Indoor Fan Motor		Oversize Indoor Fan Motor	
			Minimum Circuit Ampacity <sup>2</sup>	Maximum Fuse Size or Maximum Circuit Breaker <sup>1</sup>	Minimum Circuit Ampacity <sup>2</sup>	Maximum Fuse Size or Maximum Circuit Breaker <sup>1</sup>
12½	YCD151C3	187-253	59	70	65	80
	YCD151C4	414-506	30	35	32	40
	YCD151CW	517-633	24	30	26	30
15	YCD181C3	187-253	74	90	80	90
	YCD181C4	414-506	37	50	39	50
	YCD181CW	517-633	30	40	32	40
17½	YCD211C3	187-253	91	125	99	125
	YCD211C4	414-506	45	60	49	60
	YCD211CW	517-633	36	45	39	50
20	YCD241C3	187-253	99	125	107	125
	YCD241C4	414-506	51	60	54	70
	YCD241CW	517-633	40	50	43	50
25	YCD301C3	187-253	117	150	N/A	N/A
	YCD301C4	414-506	57	70	N/A	N/A
	YCD301CW	517-633	46	50	N/A	N/A

Notes:

1. HACR breaker per NEC.
2. MCA values do not include Power Exhaust accessory. See Table ED-7 for this information.

\*Indicates both downflow and horizontal units.



# Electrical Data

(High Efficiency)

**Table ED-9 – Unit Wiring - Dehumidification (Hot Gas Reheat) Option (Downflow Only)**

Tons	Unit Model No.	Unit Operating Voltage Range	Standard Indoor Fan Motor		Oversize Indoor Fan Motor	
			Minimum Circuit Ampacity <sup>2</sup>	Maximum Fuse Size or Maximum Circuit Breaker <sup>1</sup>	Minimum Circuit Ampacity <sup>2</sup>	Maximum Fuse Size or Maximum Circuit Breaker <sup>1</sup>
12½	YCD151C3	187-253	59	70	65	80
	YCD151C4	414-506	30	35	32	40
	YCD151CW	517-633	24	30	26	30
15	YCD181C3	187-253	71	90	77	100
	YCD181C4	414-506	36	45	39	50
	YCD181CW	517-633	28	35	30	40
20	YCD241C3	187-253	98	125	105	125
	YCD241C4	414-506	50	60	53	60
	YCD241CW	517-633	39	50	42	50

Notes:

1. HACR breaker per NEC.
2. MCA values do not include Power Exhaust accessory. See Table ED-7 for this information.

\*Indicates both downflow and horizontal units.



# Electrical Data

**Table ED-10 – Electrical Characteristics – Combustion Blower Motor**

Unit Model No.	Heat	Heating		RPM	Volts	Phase	Amps	
		Stages	HP				FLA	LRA
YC*150, 151	Low	2	1/20	3500/2800 <sup>1</sup>	208-230	1	0.5	0.78
YC*180, 181, 210, 211, 240-300	Low	2	1/10	3500/2800 <sup>1</sup>	208-230	1	0.8	2.00
YC*151-YC*301	High	2	1/10	3500/2800 <sup>1</sup>	208-230	1	0.8	2.00

1. High/Low Speed.

**Table ED-11 – Electrical Characteristics – Power Exhaust Accessory**

Tons	Accessory Operating Voltage	Phase	HP	RPM	Amps	
					FLA	LRA
12 <sup>1</sup> / <sub>2</sub> <sup>1</sup> , 12 <sup>1</sup> / <sub>2</sub> <sup>2</sup>	208-230	1	3/4	1040	6.6	13.5
15, 17 <sup>1</sup> / <sub>2</sub> , 20, 25	460	1	3/4	1040	3.2	8.4
	575	1	3/4	1040	2.1	5.2

Notes:

1. 12<sup>1</sup>/<sub>2</sub> Ton Standard Unit.
2. 12<sup>1</sup>/<sub>2</sub> Ton High Efficiency Unit.

# Jobsite Connections

---

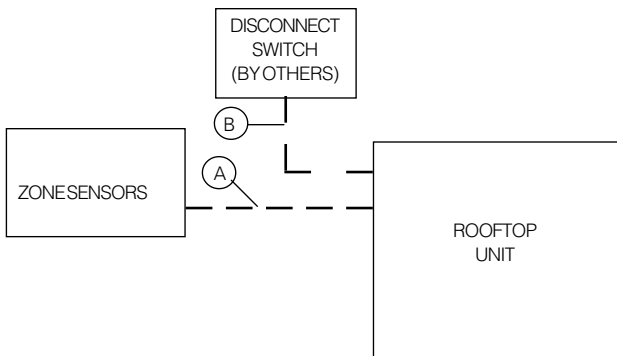

Zone Sensors  
Typical Number Of Wires

A—	Manual Changeover .....	4
	Manual/Auto Changeover .....	5
	Manual/Auto Changeover with Status Indication LED's .....	10
	Programmable Night Setback with Status Indication LED's .....	7
B—	3 Power Wires + 1 Ground Wire (three phase)	
	2 Power Wires + 1 Ground Wire (single phase)	

For specific wiring information, see the installation instructions.  
 All wiring except power wires is low voltage.  
 All customer supplied wiring to be copper and must conform to NEC or CEC and local electrical codes. Wiring shown dotted is to be furnished and installed by the customer.



# Typical Wiring

(12½ - 25 Tons)

DEVICE DESIGNATION	LEGEND	DESCRIPTION	LINE NUMBER
BMS		BUILDING MANAGEMENT SYSTEM	91
CC1CC2		COMPRESSOR CONTACTOR	64,65
CF1CF2		OUTDOOR MOTOR CAPACITOR	35,37
CFM		COMBUSTION FAN MOTOR	43
CFM		CLOGGED FILTER SWITCH	98
CPR1,CPR2		COMPRESSOR	21,26
EXF		EXHAUST FAN RELAY	
DTS		DISCHARGE TEMPERATURE SENSOR	91
ECA		ECONOMIZER ACTUATOR	93
F		FAN FAILURE SWITCH	100
F		FAN FAILURE SWITCH	100
F		INDOOR FAN CONTACTOR	17,18
RTRM		RELAY/REL OPTIIONS MODULE	
COMM		COMMUNICATION MODULE	
FTB		FAN TERMINAL BLOCK	16,17,18
GV		GAS VALVE	76
HFC1,HFC2		HIGH PRESSURE CONTROL	64,65
HTB1		HI VOLTAGE TERMINAL BLOCK	11
IDM		INDOOR FAN MOTOR	17
IGN		IGNITION CONTROL MODULE	74,50
IP		IGNITION PROBE	64
LTB		LOW VOLTAGE TERM BLOCK	50
LPC1,LPC2		LOW PRESSURE CONTROL	76,80
OAS		OUTDOOR AIR SENSOR	70
DHS		OUTDOOR HUMIDITY SENSOR	100
ODM1,ODM2		OUTDOOR FAN MOTOR	33,37
DDF1,DDF2		OUTDOOR FAN RELAY	69,68,34,35
RAS		RETURN AIR SENSOR	96
RHS		RETURN HUMIDITY SENSOR	98
RMP		REMOTE MINIMUM POSITION	66
RHT		RETURN HIGH TEMPERATURE	98
SAS		SUPPLY AIR SENSOR	91
SHT		SUPPLY HIGH TEMPERATURE	66
TCO1		HIGH LIMIT CUTOUT	72
TCO2		FAN FAILURE LIMIT	72
TNS1		CONTROL POWER TRANSFORMER	58
TNS2		IGNITION TRANSFORMER	41
XFR		EXHAUST FAN RELAY	99
ZSM		ZONE SENSOR MODULE	80
PPF3		ECONOMIZER PLUG	90-102
PPF4,PPM4		IGNITION CONTROL PLUG	50,75
PPF11,PPM11		COMBUSTION FAN MOTOR PLUG	41-46

**WARNING**  
HAZARDOUS VOLTAGE!  
DISCONNECT ALL ELECTRIC POWER INCLUDING REMOTE DISCONNECTS BEFORE SERVICING.  
FAILURE TO DISCONNECT POWER BEFORE SERVICING CAN CAUSE SEVERE PERSONAL INJURY OR DEATH.

**AVERTISSEMENT**  
VOLTAGE HASARDEUX!  
DECONNECTEZ TOUTES LES SOURCES DE COURANT ÉLECTRIQUE, Y COMPRIS LES DISCONNECTS, AVANT D'ENTREPRENDRE L'ENTRETIEN.  
ÉCHEC À DÉCONNECTER LA SOURCE ÉLECTRIQUE AVANT D'EFFECTUER L'ENTRETIEN PEUT ENTRAÎNER DES BLESSURES CORPORELLES SÈVÈRES OU LA MORT.

**CAUTION**  
USE COPPER CONDUCTORS ONLY! UNIT TERMINALS ARE NOT DESIGNED TO ACCEPT OTHER TYPES OF CONDUCTORS.  
FAILURE TO DO SO MAY CAUSE DAMAGE TO THE EQUIPMENT.

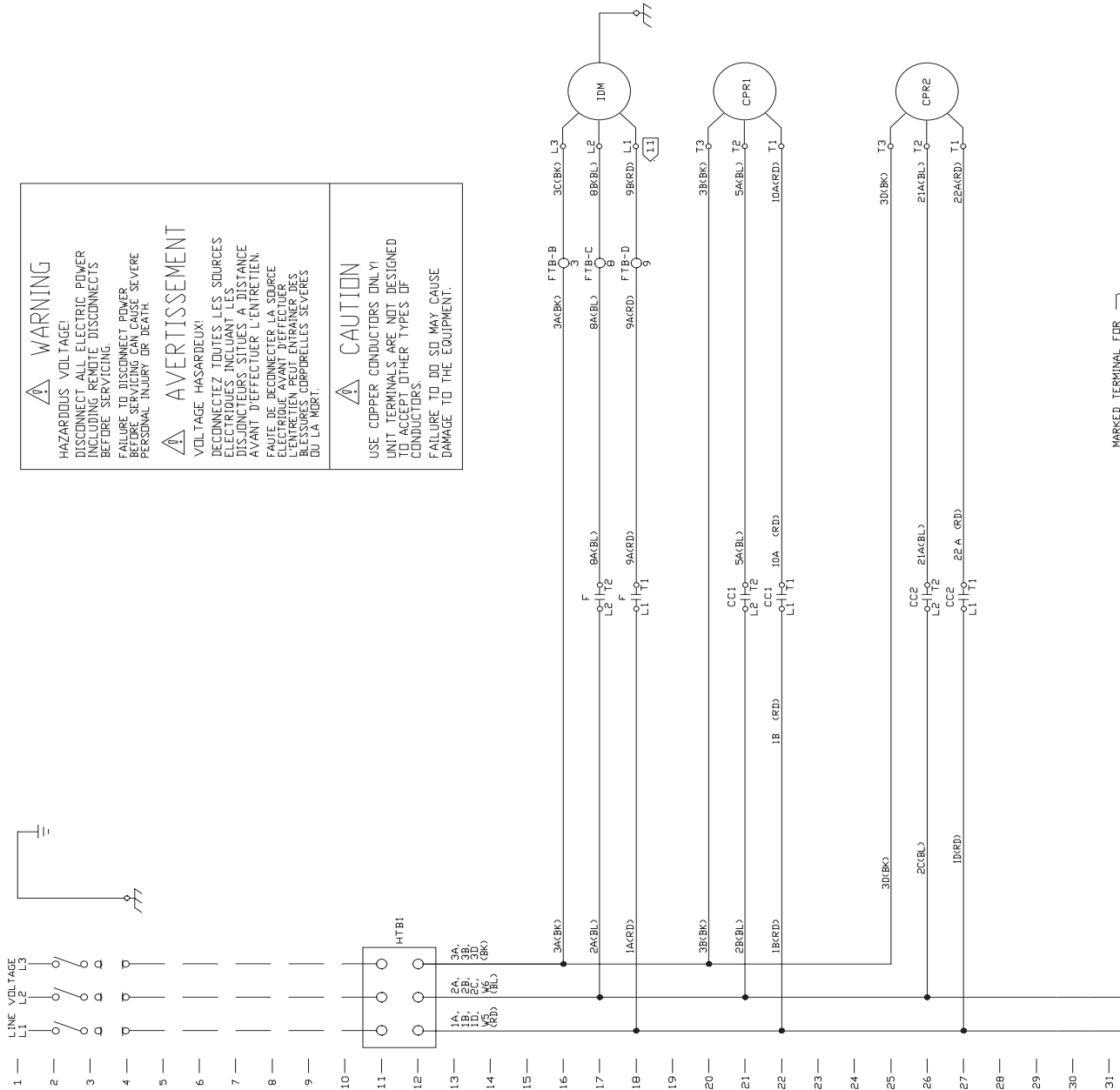

MARKED TERMINAL FOR ...

# Typical Wiring

(12½ - 25 Tons)

- NOTES:
- UNLESS OTHERWISE NOTED, ALL SWITCHES ARE SHOWN AT 25°C (77°F), AT ATMOSPHERIC PRESSURE. SWITCHES SHOULD BE TESTED AT 25°C (77°F) AFTER A NORMAL SHUTDOWN HAS OCCURRED. ALL THERMISTORS ARE 10K AT 25°C (77°F).
  - DASHED LINES INDICATE RECOMMENDED FIELD WIRING. THE FIELD PHANTOM LINE ENCLOSEURES PROVIDED BY BELVUE INDUSTRIES INDICATE COMPONENTS PROVIDED BY BELVUE INDUSTRIES. BELVUE INDUSTRIES INDICATES THE LOCATION OF CONTACTS BY LINE NUMBER AND UNDERLINED NUMBER INDICATES A NORMALLY CLOSED CONTACT.
  - NUMBERS ALONG THE RIGHT SIDE OF THE SCHEMATIC INDICATE THE LOCATION OF CONTACTS BY LINE NUMBER AND UNDERLINED NUMBER INDICATES A NORMALLY CLOSED CONTACT.
  - THREE PHASE MOTORS ARE PROTECTED UNDER PRIMARY SINGLE PHASING CONDITIONS. ALL MOTORS HAVE INTERNAL THERMAL PROTECTION. COMPRESSORS HAVE

ABBV	COLOR	DESIGNATION	ABBV	COLOR
BK	BLACK	PR	PP	PURPLE
BL	BLUE	RD	RD	RED
BR	BROWN	VH	VH	WHITE
GR	GREEN	YL	YL	YELLOW
DR	DRANGE	TN	TN	TAN

2309-3133

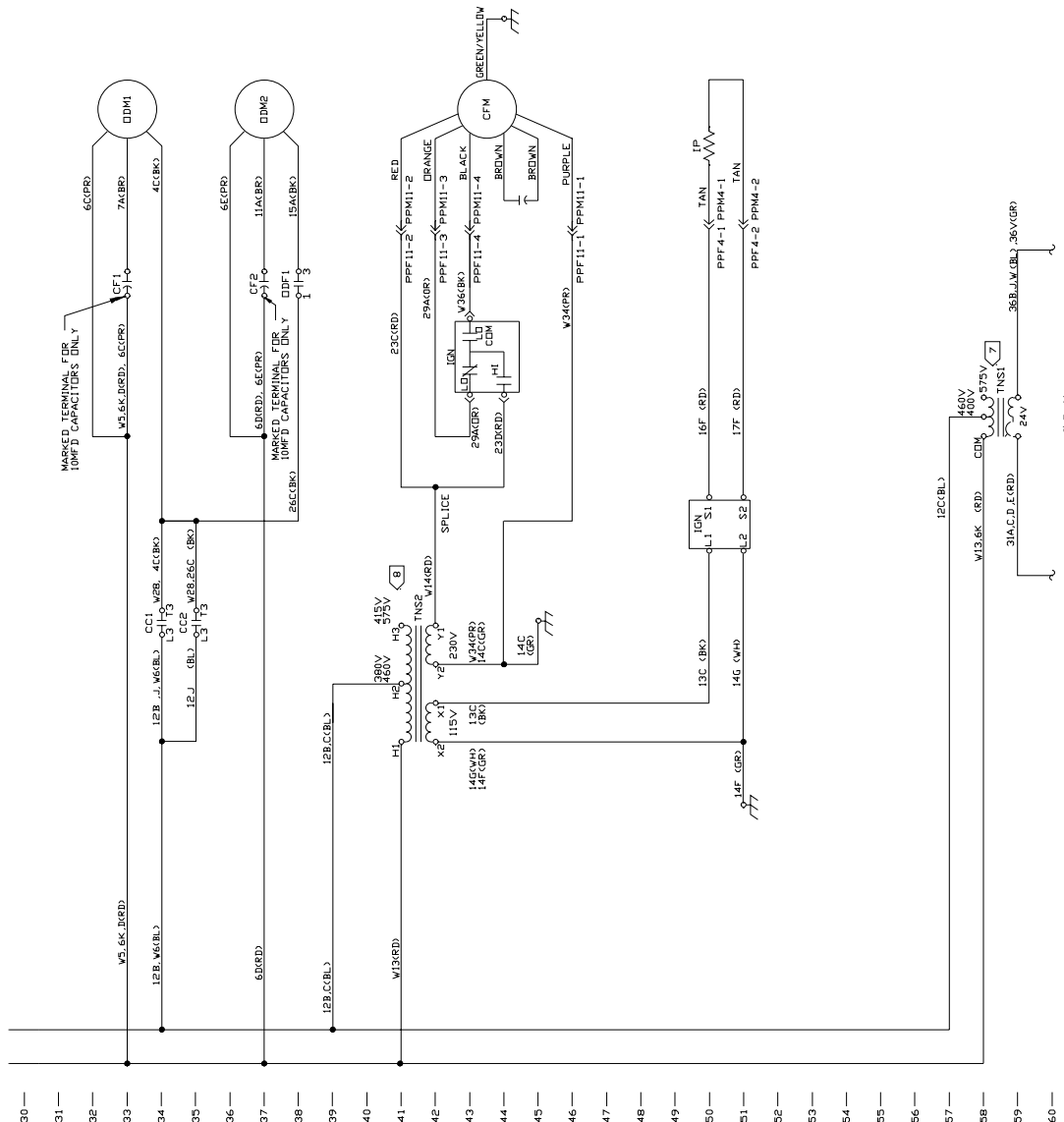

PRINTED FROM 2307-3133





# Typical Wiring

## (12½ - 25 Tons)

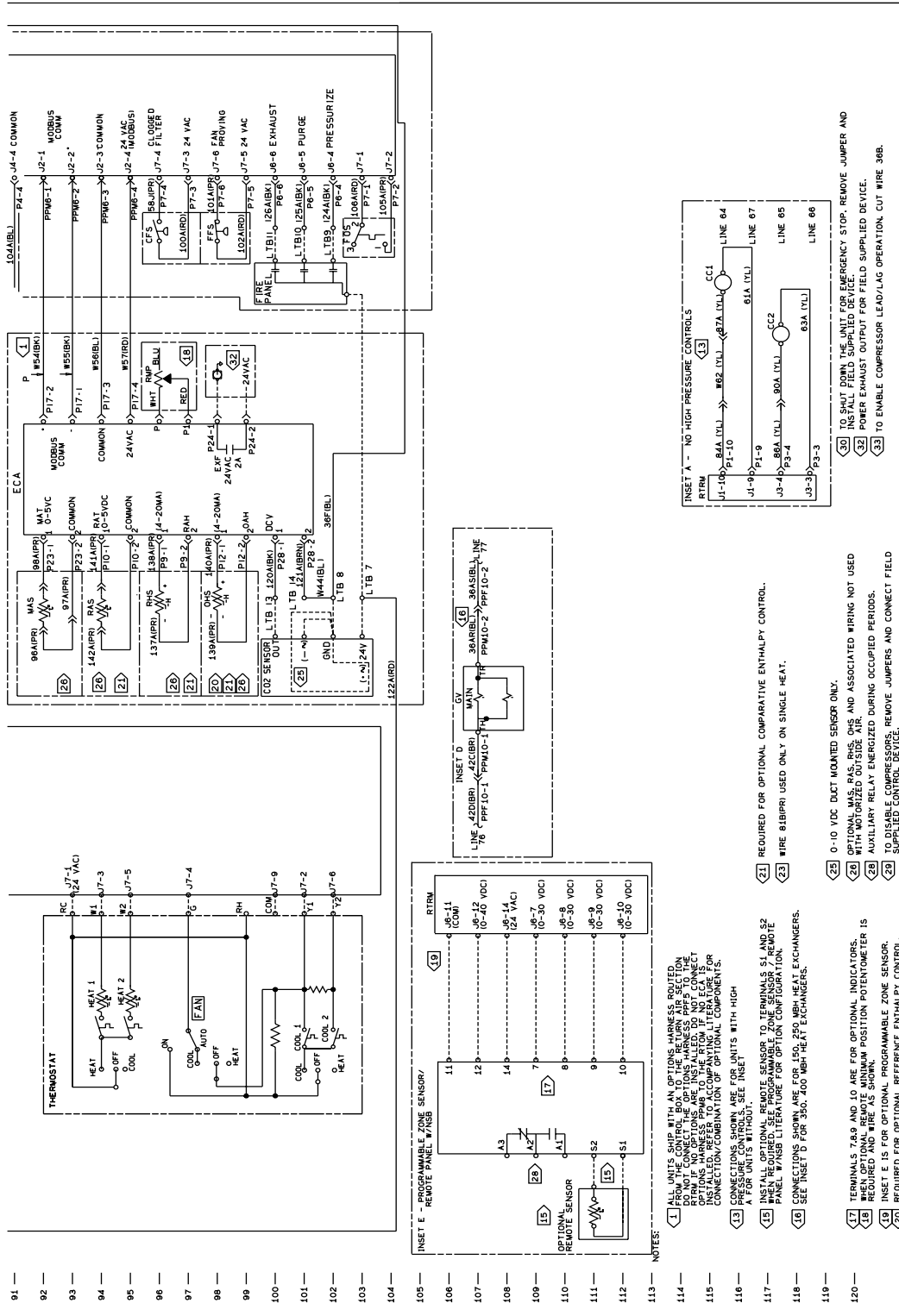

91 —  
92 —  
93 —  
94 —  
95 —  
96 —  
97 —  
98 —  
99 —  
100 —  
101 —  
102 —  
103 —  
104 —  
105 —  
106 —  
107 —  
108 —  
109 —  
110 —  
111 —  
112 —  
113 —  
114 —  
115 —  
116 —  
117 —  
118 —  
119 —  
120 —



# Dimensional Data

**12½ Ton (High Efficiency)**  
**12½, 15, 17½ Ton (Standard Efficiency)**

All dimensions are in inches.

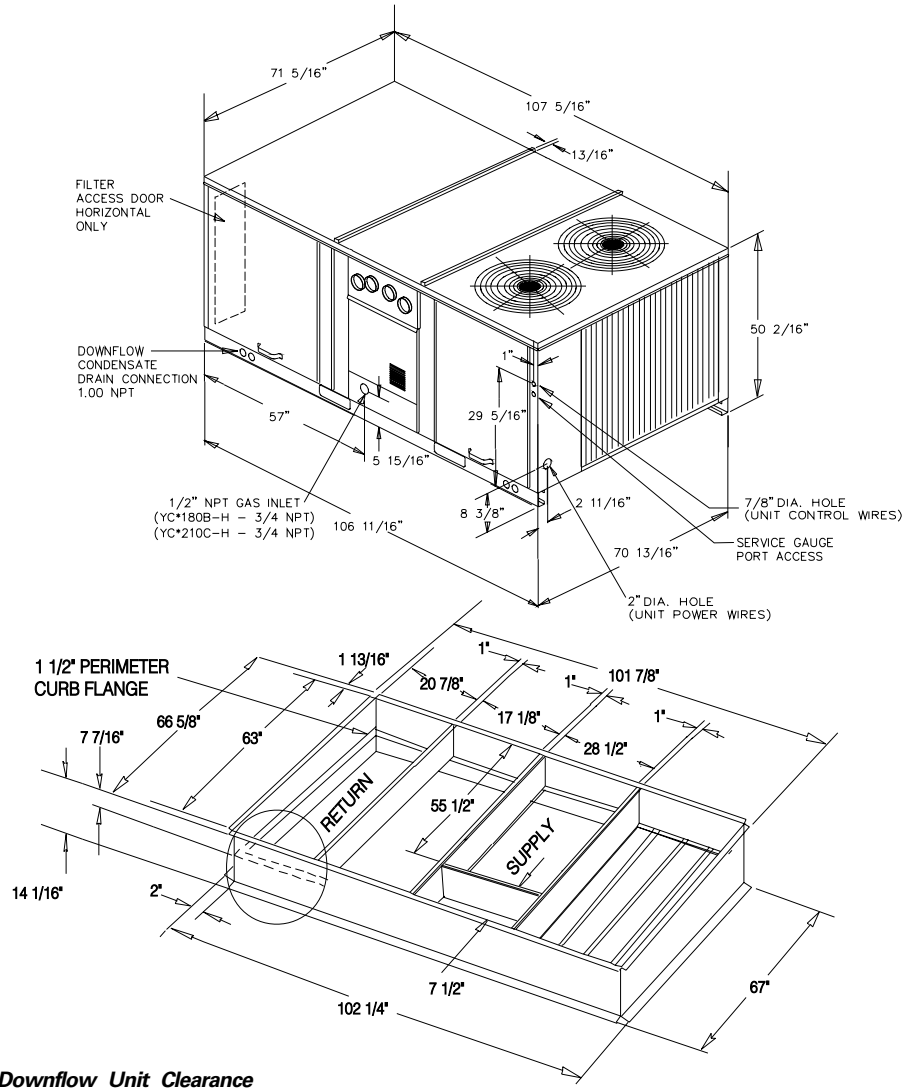

**Note:**  
 Duct flanges mount 7-7/16" down inside the curb on the 1-1/2" curb flanges. See recommended duct dimensions on the next page.  
 Roofcurb is intended for downflow use only.

**Downflow Unit Clearance**

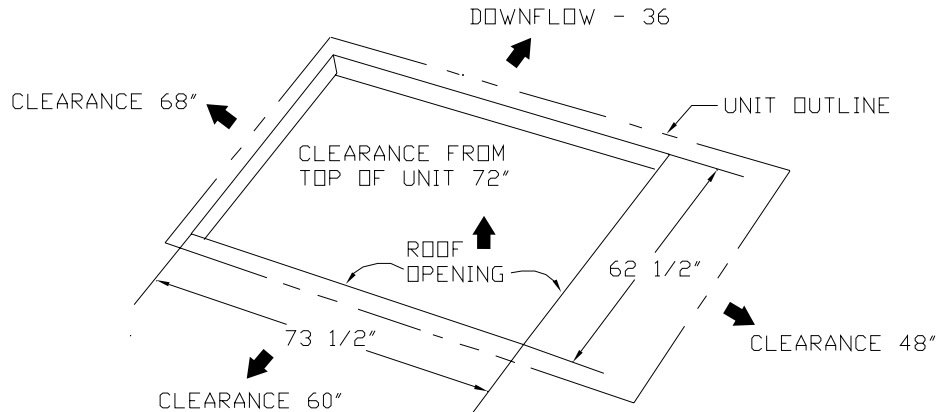

# Dimensional Data

**12½ Ton** (High Efficiency)  
**12½, 15, 17½ Ton** (Standard Efficiency)

All dimensions are in inches.

**Downflow Duct Connections – Field Fabricated**

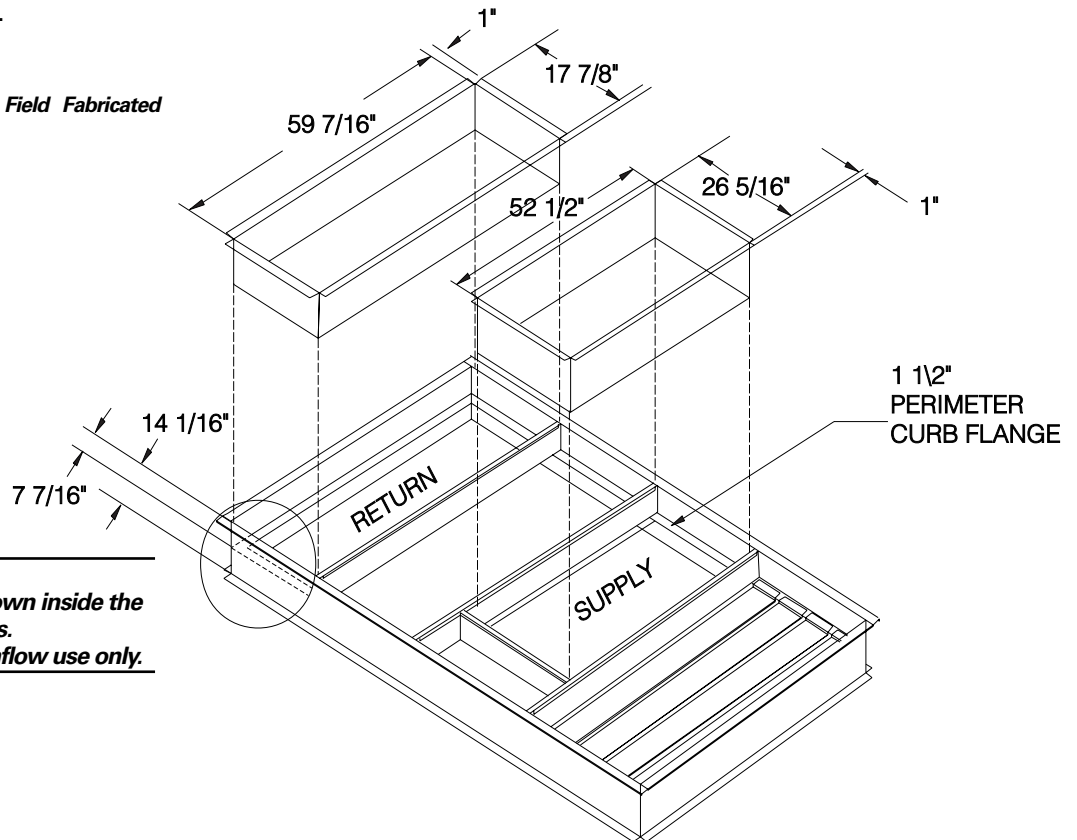

**Note:**  
 Duct flanges mount 7-7/16" down inside the curb on the 1-1/2" curb flanges.  
 Roofcurb is intended for downflow use only.

**Horizontal Unit Supply/Return and Unit Clearance**

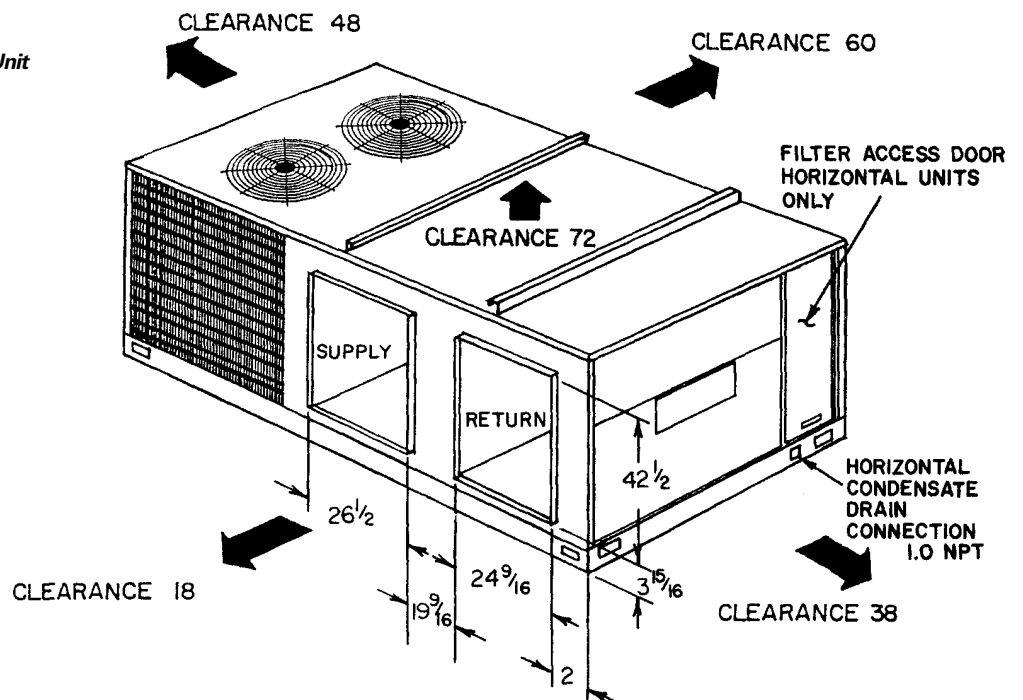



# Dimensional Data

15 - 25 Tons (High Efficiency)  
20, 25 Ton (Standard Efficiency)

All dimensions are in inches.

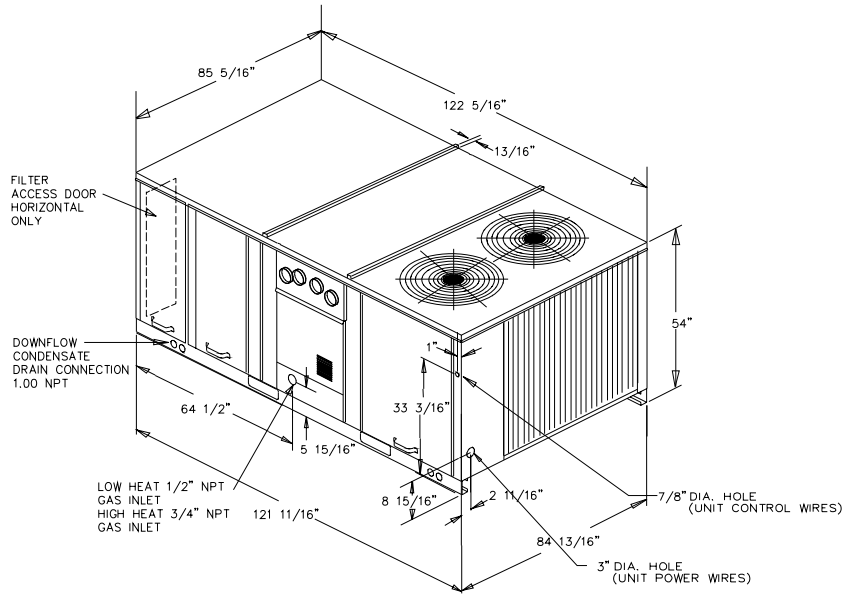

**Note:**  
Duct flanges mount 7-7/16" down inside the curb on the 1-1/2" curb flanges. See recommended duct dimensions on the next page.  
Roofcurb is intended for downflow use only.

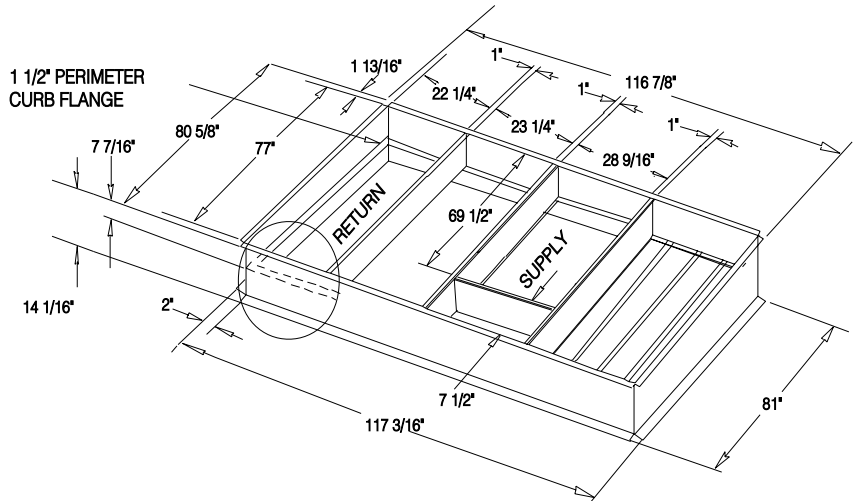

### Downflow Unit Clearance

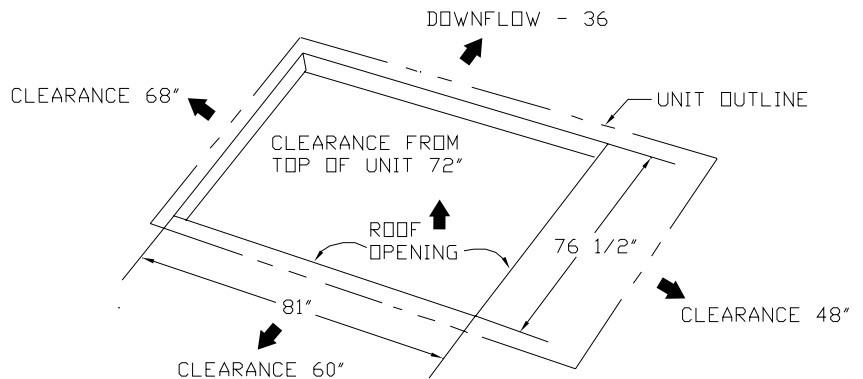

# Dimensional Data

15 - 25 Tons (High Efficiency)  
20, 25 Ton (Standard Efficiency)

All dimensions are in inches.

**Downflow Duct Connections – Field Fabricated**

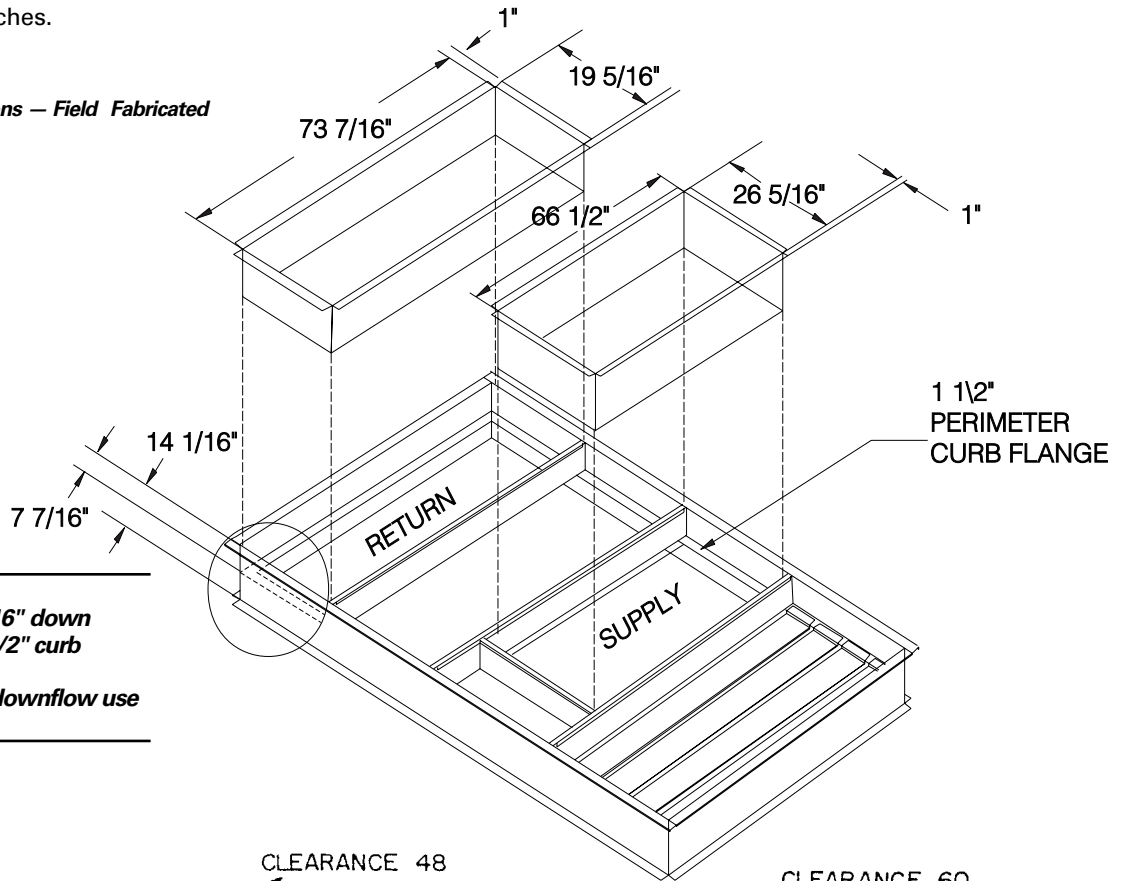

**Note:**  
Duct flanges mount  $7\text{-}7/16$ " down inside the curb on the  $1\text{-}1/2$ " curb flanges.  
Roofcurb is intended for downflow use only.

**Horizontal Unit Supply/Return and Unit Clearance**

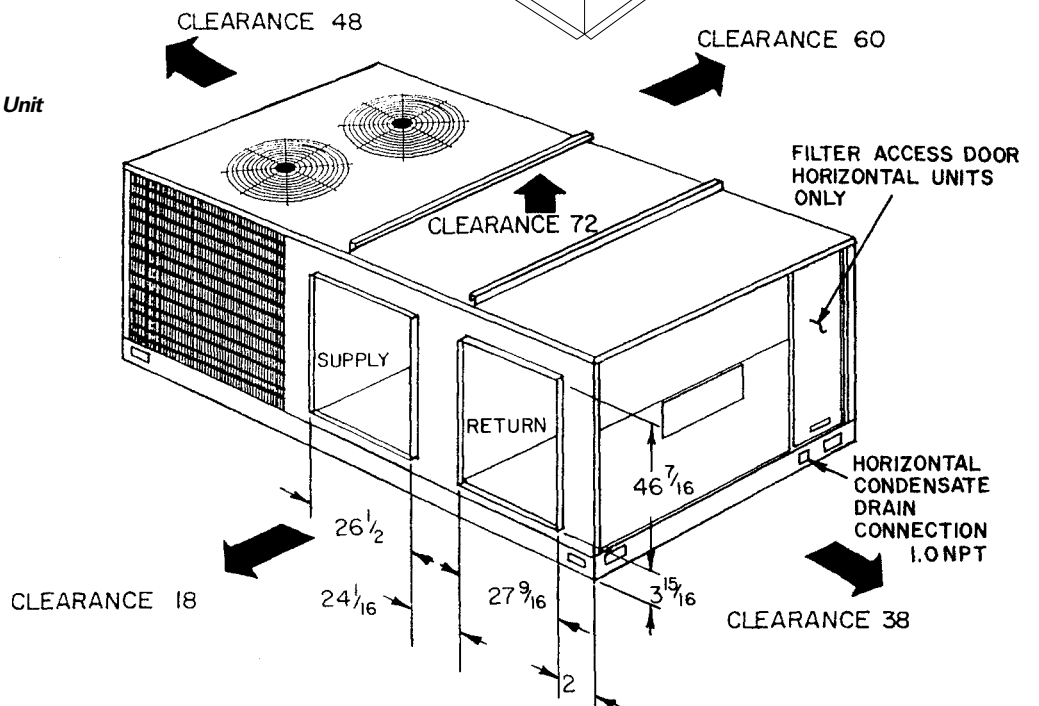



# Dimensional Data

# (12½ - 25 Tons) Accessories

All dimensions are in inches.

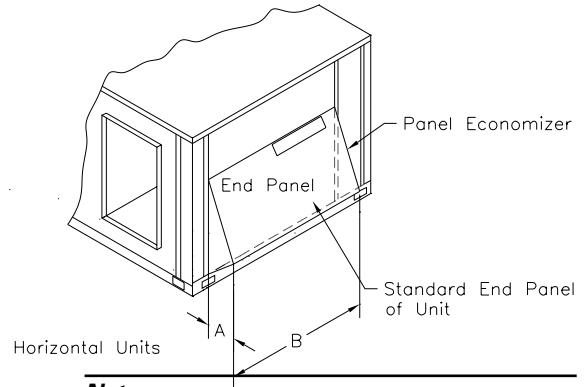
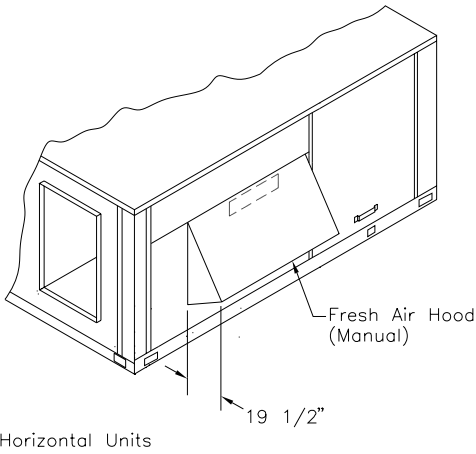

**Note:**  
**When applying economizer to horizontal units, connecting ductwork must be run full size to allow proper operation of economizer damper.**

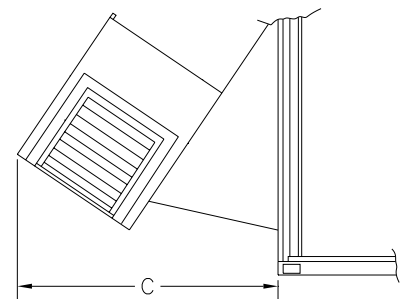
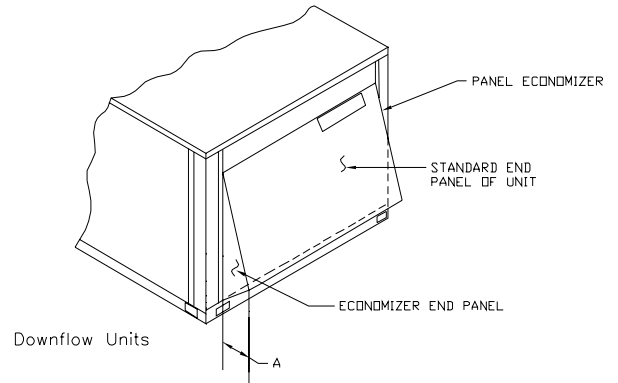
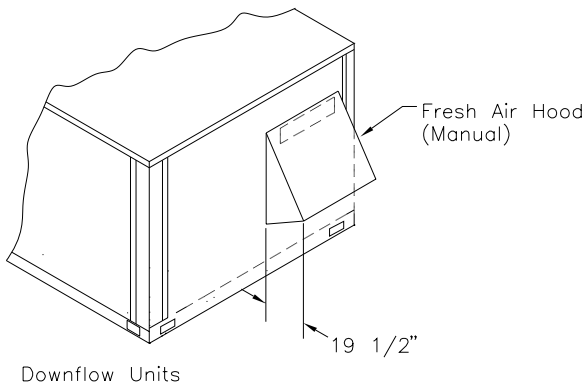

Power Exhaust with Downflow Economizers Only, Side View

**Table DD-1**

Unit Model #	A	B <sup>1</sup>	C <sup>2</sup>
YC*150-151-180,210	17½	53¾	36
YC*181, 211-301	19½	64¾	39

Notes:  
1. Horizontal dimension only. Downflow economizer is width of end panel.  
2. Power exhaust is applied on downflow economizer only.

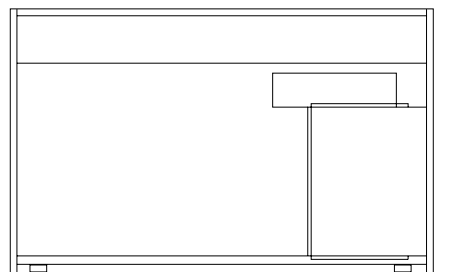

Power Exhaust with Downflow Economizers Only. End Panel View

# Dimensional Data

# Factory Installed Options (FIOPS)

All dimensions are in inches.

**Table DD-2**

Unit	A	B	C
Model #			
YCD150, 151, 180, 210	42 <sup>3</sup> / <sub>8</sub>	66 <sup>3</sup> / <sub>8</sub>	48 <sup>3</sup> / <sub>8</sub>
YCD181-300	29 <sup>1</sup> / <sub>2</sub>	77 <sup>1</sup> / <sub>8</sub>	58

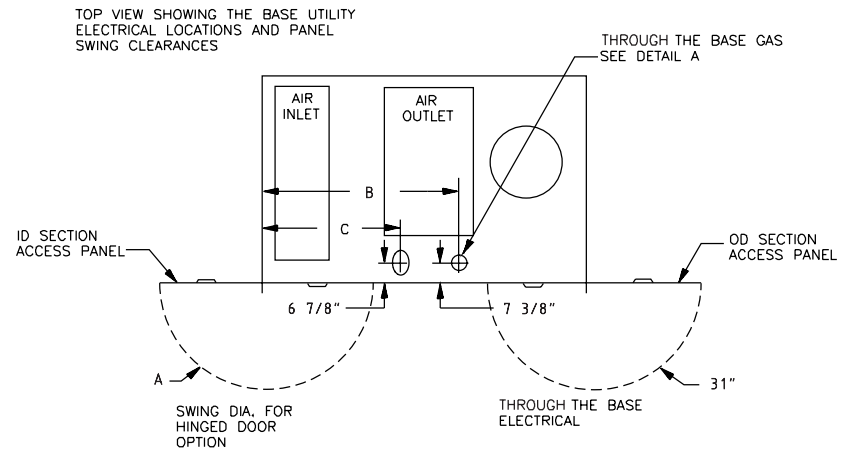

HEIGHT OF GAS PIPE REQUIRED FROM INSIDE BASE OF UNIT TO GAS SHUT OFF ASSEMBLY (FACTORY PROVIDED)

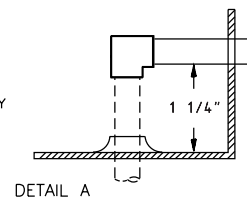

# Dimensional Data

# Factory Installed Options (FIOPS)



*Fan Failure Switch*

*Clogged Filter Switch*



*Disconnect Switch or Circuit Breaker*

*Powered Or Unpowered Convenience Outlet*

*Hinged Access Door*

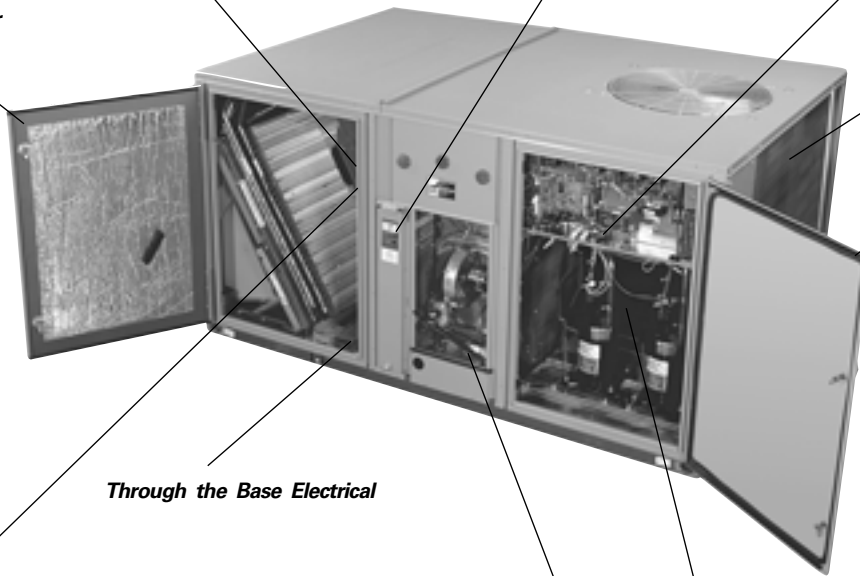

*Trane Communication Interface*

*Black Epoxy Coated Outdoor Coils*

*Hinged Access Door*

*Through the Base Electrical*

*High Pressure Cut Out*



*Supply and/or Return Smoke Detectors*



*Through the Base Gas Piping*



# Dimensional Data

## (12½ - 25 Tons)

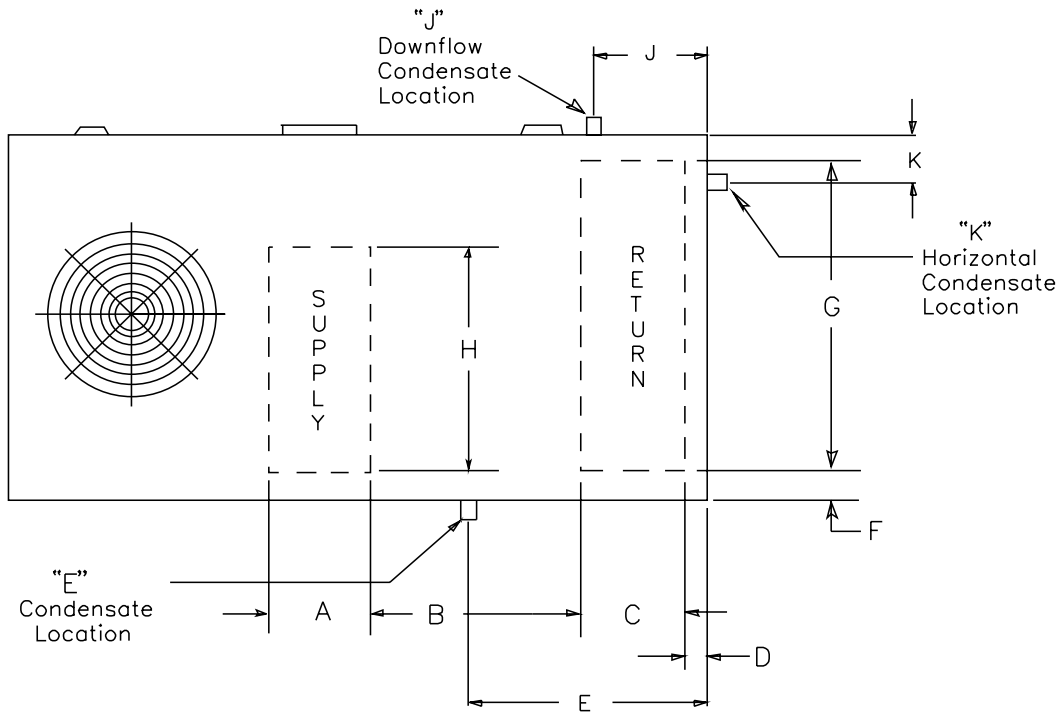

**Table DD-3 – Standard Efficiency Units**

Tons	Downflow Only							Condensate Drain Size	Condensate Drain Location			
									Downflow		Horizontal	
									E	J	E	K
12½, 15, 17½	A	B	C	D	F	G	H	1 NPT	–	25-5/8	–	5-3/8
20, 25	26-7/16	22-1/2	18-11/16	4-1/4	4-1/4	62-7/16	54-11/16	1 NPT	–	26-3/4	–	5-3/8

**Table DD-4 – High Efficiency Units**

Tons	Downflow Only							Condensate Drain Size	Condensate Drain Location			
									Downflow		Horizontal	
									E	J	E	K
12½	A	B	C	D	F	G	H	1 NPT	–	25-5/8	–	6
15-25	26-7/16	22-1/2	18-11/16	4-1/4	4-1/4	62-7/16	54-11/16	1 NPT	–	26-3/4	–	5-3/8



# Weights

(12½ - 25 Tons)

**Table W-1 — Accessory Net Weights (Lbs)<sup>1,2</sup>**

Unit Model No.	Economizer		Outside Air Damper		Roof <sup>3</sup>	Oversize Motor	LPG Conversion	All Zone	Power <sup>3</sup>	High <sup>4</sup> Static	Low <sup>4</sup> Static
	Net	Motorized	Manual	Curb	Adder	Kit	Sensors	Exhaust	Drive	Drive	
YCD150D,151C YCD180B,210C	65	60	32	205	5	5	1	95	2	2	
YCD181,211,241C YCD240B YCD300B,301C	80	75	32	235	5	5	1	95	2	—	
YCH150D,151C YCH180B,210C	50	60	32	N/A	5	5	1	N/A	2	—	
YCH181,211,241C YCH240B	65	75	32	N/A	5	5	1	N/A	2	—	
YCH300B, 301C	65	75	32	N/A	—	5	1	N/A	—	2	

**Notes:**

1. Net weight should be added to unit weight when ordering factory installed accessories.
2. YC\* 150-300 factory installed options for economizers, multiply net capacity x .99, EER x .97.  
For oversize motors, multiply net capacity x .98, EER x .93. This is provided in compliance with ARI certification program.
3. Downflow only.
4. Not available on all models (See fan performance tables for specific models).

**Table W-2 — Factory Installed Options (FIOPS) Net Weights (Lbs)<sup>1,2,3</sup>**

Accessory	Weight	Unit Model Number
High Efficiency Motors <sup>4</sup>	49	YC*150-181 standard size motor
	36	YC*211-241 standard size motor
		YC*150-181 oversize motor
	0	YC*300-301 standard size motor
Hinged Doors	27	All YC* units
Powered Convenience Outlet	38	All YC* units
Through the Base Electrical	23	All YC* units
Unit Mounted Circuit Breaker	5	All YC* units
Unit Mounted Disconnect	5	All YC* units
Smoke Detectors		
	Supply/Return	5
Tool-less Hail Guard	38	YC*150,151,180,210
	43	YC*181,211,240,241,300,301
Novar 2024	7	All YC* units
Novar 3501	5	All YC* units

**Notes:**

1. Weights for FIOP accessories not listed are <5 lbs.
2. Net weight should be added to unit weight when ordering factory installed accessories.
3. See Table W-1 for standard factory installed economizer and oversized motors.
4. Standard factory installed motors are already included in unit net and shipping weights. Values shown for high efficiency motors are in addition to the standard motor weight.

\*Indicates both downflow and horizontal units.

# Weights

## (12½ - 25 Tons)

**Table W-3 — Maximum Unit And Corner Weights (Lbs) and Center Of Gravity Dimensions (In.)**

Tons	Unit Model No.	Maximum Weights (Lbs) <sup>2</sup>		Corner Weights (Lbs) <sup>1</sup>				Center of Gravity (In.)	
		Shipping	Net	A	B	C	D	Length	Width
12½	YC*150D/YC*151C	1826/1915	1458/1547	495/523	373/383	254/271	336/370	46/45	29/30
	YC*151C (Reheat Units)	1870/1959	1502/1591	506/534	384/394	265/282	347/381	46/45	29/30
15	YC*180B/YC*181C	2033/2464	1665/2005	600/686	395/504	266/345	404/470	43/52	29/35
	YC*181C (Reheat Units)	2097/2528	1729/2069	611/697	406/515	277/356	415/481	43/52	29/35
17½	YC*210C/YC*211C	2189/2547	1821/2088	618/701	463/538	317/369	424/480	46/53	29/35
20	YC*240B/YC*241C	2547/2645	2088/2186	738/751	526/568	343/373	481/494	51/53	34/34
	YC*241C (Reheat Units)	2567/2665	2108/2206	743/756	531/573	348/378	486/499	51/53	34/34
25	YC*300B/YC*301C	2541/2650	2082/2191	721/755	552/569	351/373	458/495	53/53	33/34

**Notes:**

1. Corner weights are given for information only. 12½-25 ton must be supported continuously by a curb or equivalent frame support.
2. Weights are approximate. Horizontal and downflow unit and corner weights may vary slightly.

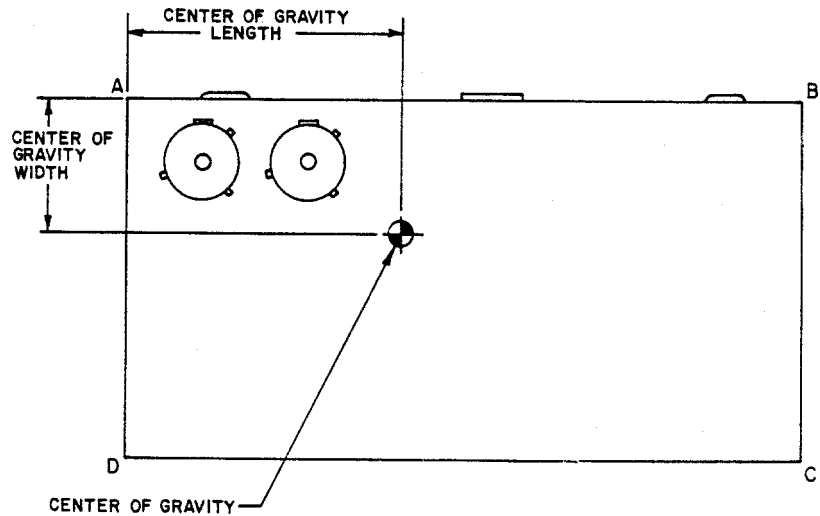

\*Indicates both downflow and horizontal units.



# Mechanical Specifications

## General

The units shall be dedicated downflow or horizontal airflow. The operating range shall be between 115°F and 0°F in cooling as standard from the factory for all units. Cooling performance shall be rated in accordance with ARI testing procedures. All units shall be factory assembled, internally wired, fully charged with R-22, and 100 percent run tested to check cooling operation, fan and blower rotation and control sequence, before leaving the factory. Wiring internal to the unit shall be colored and numbered for simplified identification. Units shall be UL listed and labeled, classified in accordance to UL 1995/CAN/CSA No. 236-M90 for Heat Pumps. Canadian units shall be CSA Certified.

## Casing

Unit casing shall be constructed of zinc coated, heavy gauge, galvanized steel. Exterior surfaces shall be cleaned, phosphatized, and finished with a weather-resistant baked enamel finish. Unit's surface shall be tested 500 hours in a salt spray test in compliance with ASTM B117. Cabinet construction shall allow for all maintenance on one side of the unit. In order to ensure a water and air tight seal, service panels shall have lifting handles and no more than three screws to remove. All exposed vertical panels and top covers in the indoor air section shall be insulated with a 1/2 inch, 1 pound density foil-faced, fire-resistant, permanent, odorless, glass fiber material. The base of the downflow unit shall be insulated with 1/2 inch, 1 pound density foil-faced, closed-cell material. The downflow unit's base pan shall have no penetrations within the perimeter of the curb other than the raised 1<sup>1</sup>/<sub>8</sub> inch high supply/return openings to provide an added water integrity precaution, if the condensate drain backs up. The base of the unit shall have provisions for forklift and crane lifting.

## Unit Top

The top cover shall be one piece, or where seams exist, double hemmed and gasket sealed to prevent water leakage.

## Filters

Two inch standard filters shall be factory supplied on all units. Optional two inch pleated media filters shall be available.

## Compressors

All units shall have direct-drive, hermetic, scroll type compressors with centrifugal type oil pumps. Motor shall be suction gas-cooled and shall have a voltage utilization range of plus or minus 10 percent of nameplate voltage. Internal overloads shall be provided with the scroll compressors. All models shall have crankcase heaters, low and high pressure control as standard.

## Refrigerant Circuits

Each refrigerant circuit shall have independent fixed orifice or thermostatic expansion devices, service pressure ports, and refrigerant line filter driers factory installed as standard. An area shall be provided for replacement suction line driers.

## Evaporator and Condenser Coils

Internally finned, 3/8" copper tubes mechanically bonded to a configured aluminum plate fin shall be standard. Coils shall be leak tested at the factory to ensure the pressure integrity. The evaporator coil and condenser coil shall be leak tested to 200 psig and pressure tested to 450 psig. All dual compressor units shall have intermingled evaporator coils. Sloped condensate drain pans are standard. Patent-pending 1+1+1 condenser coil, permanently gapped for easy cleaning is available.

## Gas Heating Section

The heating section shall have a drum and tube heat exchanger design using corrosion resistant steel components. A forced combustion blower shall supply premixed fuel to a single burner ignited by a pilotless hot surface ignition system. In order to provide reliable operation, a negative pressure gas valve shall be used that requires blower operation to initiate gas flow. On an initial call for heat, the combustion blower shall purge the heat exchanger 45 seconds before ignition. After three unsuccessful ignition attempts, the entire heating system shall be locked out until manually reset at the thermostat. Units shall be suitable for use with natural gas or propane (field installed kit) and shall also comply with California requirements for low NOx emissions. The 12<sup>1</sup>/<sub>2</sub>-25 tons shall have two stage heating.

## Outdoor Fans

The outdoor fan shall be direct-drive, statically and dynamically balanced, draw-through in the vertical discharge position. The fan motor(s) shall be permanently lubricated and shall have built-in thermal overload protection.

## Indoor Fan

Units above shall have belt driven, FC centrifugal fans with adjustable motor sheaves. Units with standard motors shall have an adjustable idler-arm assembly for quick-adjustment of fan belts and motor sheaves. All motors shall be thermally protected. Oversized motors shall be available for high static application. All indoor fan motors meet the U.S. Energy Policy Act of 1992 (EPACT).

# Mechanical Specifications

---

## Controls

Unit shall be completely factory wired with necessary controls and contactor pressure lugs or terminal block for power wiring. Unit shall provide an external location for mounting a fused disconnect device. ReliaTel controls shall be provided for all 24 volt control functions. The resident control algorithms shall make all heating, cooling, and/or ventilating decisions in response to electronic signals from sensors measuring indoor and outdoor temperatures. The control algorithm maintains accurate temperature control, minimizes drift from set point, and provides better building comfort. A centralized control shall provide anti-short cycle timing and time delay between compressors to provide a higher level of machine protection.

## Defrost Controls

Adaptive demand defrost shall be provided to permit defrost wherever coil icing conditions begin to significantly reduce unit capacity.

## Factory Installed Options

### Black Epoxy Coated Condenser Coil

The coil provides corrosion protection to condenser coils for seacoast application. The protection is a thermoset vinyl coating, bonded to normal aluminum fin stock. The uniform thickness of the bonded vinyl layer exhibits excellent corrosion protection in salt spray tests performed in accordance with ASTM B117.

### Dehumidification Option

The dehumidification (hot gas reheat) option shall provide increased dehumidification. The option shall consist of a hot-gas reheat coil located on the leaving air side of the evaporator coil prepiped and circuited. Low pressure switch(es) and thermostatic expansion valve(s) TXV are standard. Froststat™, ReliaTel options module, and 2" pleated filters are required but not standard. They must be ordered and configured separately.

## Hinged Access Doors

Sheet metal hinges are available on the Filter/Evaporator Access Door and the Compressor/Control Access Door. This option is available on all downflow models.

## High Efficiency Motors

This option is available with efficiency ratings from 86.5 up to 91.0. It is not available for all models.

## High Pressure Cutout

This option is offered for units that do not have High Pressure cutout as standard.

## Powered or Unpowered Convenience Outlet

This option is a GFCI, 120v/15amp, 2 plug, convenience outlet, either powered or unpowered. When the convenience outlet is powered, a service receptacle disconnect will be available. The convenience outlet is powered from the line side of the disconnect or circuit breaker, and therefore will not be affected by the position of the disconnect or circuit breaker. This option can only be ordered when the Through the Base Electrical with either the Disconnect Switch, or Circuit Breaker, option is ordered. This option is available on all downflow models.

## Supply and/or Return Air Smoke Detector

With this option installed, if smoke is detected, all unit operation will be shut down. Reset will be manual at the unit. Return Air Smoke Detectors require minimum allowable airflow when used with certain models. See the Installation, Operation, and Maintenance (IOM) manual for the models affected and the minimum allowable airflow required. This option is available on all downflow models.

## Through the Base Electrical with Circuit Breaker

This option is a thermal magnetic, molded case, HACR Circuit Breaker with provisions for through the base electrical connections. The circuit breaker will be installed in a water tight enclosure in the unit with access through a swinging door. Factory wiring will be provided from the switch to the unit high voltage terminal block. The circuit breaker will provide overcurrent protection, be sized per NEC and UL guidelines, and be agency recognized by UL/CSA. This option is available on all downflow models.

## Through the Base Electrical With Disconnect Switch

Three-pole, molded case, disconnect switch with provisions for through the base electrical connections are available. The disconnect switch will be installed in the unit in a water tight enclosure with access through a swinging door. Factory wiring will be provided from the switch to the unit high voltage terminal block. The switch will be UL/CSA agency recognized. **Note:** The disconnect switch will be sized per NEC and UL guidelines but will not be used in place of unit overcurrent protection. This option is available on all downflow models.

## Through the Base Utilities Access

An electrical service entrance shall be provided allowing electrical access for both control and main power connections inside the curb and through the base of the unit. Option will allow for field installation of liquid-tight conduit and an external field installed disconnect switch.

## Two-Inch Pleated Filters

Two inch pleated media filters shall be available on all models.



# Mechanical Specifications

## Factory or Field Installed Options

### Clogged Filter/Fan Failure Switch

A dedicated differential pressure switch is available to achieve active fan failure indication and/or clogged filter indication. These indications will be registered with either a zone sensor with status indication lights or an Integrated Comfort™ System.

### Differential Pressure Switches

These options allow for individual fan failure and dirty filter indication. The fan failure switch will disable all unit functions and “flash” the Service LED on the zone sensor. The dirty filter switch will light the Service LED on the zone sensor and will allow continued unit operation.

### Discharge Air Sensing Kit

This kit provides true discharge air sensing in heating models. This sensor is a status indicator readable through Tracer™ or Tracker™. The kit is functional only with the ReliaTel Options Module.

### Economizer - Downflow

The assembly includes fully modulating 0-100 percent motor and dampers, barometric relief, minimum position setting, preset linkage, wiring harness with plug, fixed dry bulb and spring return actuator. The barometric relief damper shall be standard with the downflow economizer and shall provide a pressure operated damper that shall be gravity closing and shall prohibit entrance of outside air during the equipment “off” cycle. Solid state enthalpy and differential enthalpy control shall be field-installed

### Electric Heaters

Electric heat modules shall be available for installation within the basic unit. Electric heater elements shall be constructed of heavy-duty nickel chromium elements internally delta connected for 240 volt, wye connected for 480 and 600 volt. Staging shall be achieved through ReliaTel. Each heater package shall have automatically reset high limit control operating through heating element contactors. All heaters shall be individually fused from the factory, where required, and shall meet all NEC and CEC requirements when properly installed. Power assemblies shall provide single-point connection. Electric heat modules shall be UL listed or CSA certified. If ordering the Through the Base Electrical option with an Electric Heater, the heater must be factory installed.

### Frostat

This option is to be utilized as a safety device. The Frostat opens when temperatures on the evaporator coil fall below 10°F. The temperature will need to rise to 50°F before closing. This option should be utilized in low airflow or high outside air applications.

### LonTalk® Communications Interface

The LonTalk communications interface, when installed in a Voyager unit, allows the unit to communicate as a Tracer™ LCI-V device or directly with generic LonTalk Network Building Automation System Controls.

### Oversized Motors

Oversized motors shall be available for high static applications.

### Reference or Comparative Enthalpy

Reference Enthalpy is used to measure and communicate outdoor humidity. The unit receives and uses this information to provide improved comfort cooling while using the economizer. Comparative Enthalpy measures and communicates humidity for both outdoor and return air conditions, and return air temperature. The unit receives and uses this information to maximize use of economizer cooling, and to provide maximum occupant comfort control. Reference or Comparative Enthalpy option shall be available when a factory or field installed Downflow Economizer is ordered. This option is available on all downflow models.

### Tool-less Hail Guards

Tool-less, hail protection quality coil guards are available for condenser coil protection.

### Trane Communication Interface

This factory or field-installed option shall be provided to interface ReliaTel™ controlled units with the Trane Integrated Comfort™ systems.

# Mechanical Specifications

---

## Field Installed Options

### CO<sub>2</sub> Sensing

The CO<sub>2</sub> sensor has the ability to monitor space occupancy levels within the building by measuring the parts per million of CO<sub>2</sub> (Carbon Dioxide) in the air. As the CO<sub>2</sub> levels increase, the outside air damper modulates to meet the CO<sub>2</sub> space ventilation requirements.

### Digital Display Zone Sensor

The Digital LCD (Liquid Crystal Display) zone sensor has the look and functionality of standard zone sensors. This sensor includes a digital display of set point adjustment and space temperature in F (Fahrenheit) or C (Celsius). Includes FAN and SYSTEM buttons (supports the service functions of the standard sensor). E-squared memory stores last programmed set points. Requires 24 VAC (Volts AC). This sensor should be utilized with ReliaTel™ controls.

### Dual Thermistor Remote Zone Sensor

This sensor will allow the customer to reduce the total number of remote sensors to obtain space temperature averaging. This sensor should be utilized with ReliaTel controls.

### High Static Drive

The high static drive option shall allow the standard motor on the 12½ and 20 ton units to operate with improved external static capabilities.

### Manual Outside Air Damper

The rain hood and screen shall provide up to 25 percent outside air.

### Motorized Outside Air Dampers

Manually set outdoor air dampers shall provide up to 50 percent outside air. Once set, outdoor air dampers shall open to set position when indoor fan starts. The damper shall close to the full closed position when indoor fan shuts down.

### Powered Exhaust

The powered exhaust shall provide exhaust of return air, when using an economizer, to maintain better building pressurization.

### Roof Curb - Downflow

The roof curb shall be designed to mate with the downflow unit and provide support and a water tight installation when installed properly. The roof curb design shall allow field-fabricated rectangular supply/return ductwork to be connected directly to the curb. Curb design shall comply with NRCA requirements. Curb shall be shipped knocked down for field assembly and shall include wood nailer strips.

### Economizer - Horizontal

The horizontal economizer shall contain the same features as the downflow economizer with the exception of barometric relief.

### Remote Potentiometer

The minimum position setting of the economizer shall be adjusted with this accessory.

### Ventilation Override Accessory

With the Ventilation Override Accessory installed, the unit can be set to transition up to 3 different pre-programmed sequences for Smoke Purge, Pressurization, and Exhaust. The transition occurs when a binary input on the RTOM is closed (shorted). This would typically be a hard wired relay output from a smoke detector or fire control panel.

### Zone Sensors

This option shall be provided to interface with the Micro equipped Voyagers and shall be available in either manual, automatic, programmable with night setback, with system malfunction lights or remote sensor options.



\*High Efficiency Units only



**TRANE®**

**Trane**  
**A business of American Standard Companies**  
**[www.trane.com](http://www.trane.com)**

For more information contact your local dealer (distributor), local district office, or e-mail us at [comfort@trane.com](mailto:comfort@trane.com)

---

Literature Order Number	RT-PRC001-EN
File Number	PL-UN-RT-YCD/YCH 12½-25 TONS-PRC001-EN-10-04
Supersedes	PL-UN-RT-YCD/YCH 12½-25 TONS-PRC001-EN-07-04
Stocking Location	07-04 Webb/Mason 10-04 Electronic Only

---

Trane has a policy of continuous product and product data improvement and reserves the right to change design and specifications without notice.